

YCW3 Series

Intelligent Conventional Circuit
Breaker

OPERATION INSTRUCTION

Standard: **IEC 60947-2**

CNC

Deliver
Power For Better Life

 Before installing and using this product, please read this manual carefully and pay more attention to safety.

Contents

1 PURPOSE AND TYPE.....	(1)
2 NORMAL WORKING CONDITION AND INSTALLATION CONDITION	(1)
3 TECHNICAL DATA AND PERFORMANCE.....	(2)
4 STRUCTURE OVERVIEW	(7)
5 WIRING DIAGRAM	(11)
6 OVERALL AND MOUNTING DIMENSIONS	(21)
7 INSTALLATION, USE AND MAINTENANCE.....	(29)
8 FAILURE ANALYSIS AND RECOVERY.....	(31)
9 ORDER INSTRUCTION.....	(33)
10 PROMISE.....	(33)

YCW3 series intelligent conventional circuit breaker

1. Purpose and type

1.1 Purpose

The rated alternating voltage of YCW 3 series intelligent conventional circuit breaker (hereinafter referred to as circuit breaker) is 50Hz, 400V and 660V and the rated current is 200A~6300A. It's mainly used to distribute electric energy and protect line and power equipment from overload, under voltage, short circuit and grounding failure. Its core parts should be intelligent release with precise choosing protection, which can avoid unnecessary power failure and improve the reliability of power.

1.2 Type meaning

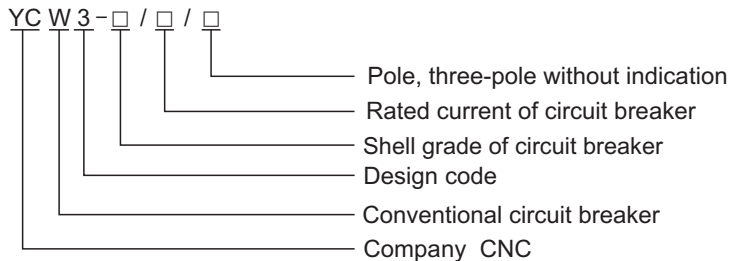

1.3 Type

Installation method: fixed and draw-out.

Operation method: electric operation and manual operation.

Release type: intelligent release, under-voltage instantaneous (time delay) release and shunt release.

1.4 Function of intelligent release

a) It has protection functions such as overload long-time delay inverse, short-time delay inverse, short-time delay definite time lag and instantaneous operation, which can be set by users to constitute protection character.

b) Grounding failure protection;

c) Overload alarm;

d) Testing; e) Load monitoring;

g) Self-diagnosis; h) MRC function;

i) Thermo-analogue;

j) Contact wearing indication;

2. Normal working condition and installation condition

2.1 The surrounding temperature should be $-5^{\circ}\text{C} \sim +40^{\circ}\text{C}$ and the average value should be not higher than $+35^{\circ}\text{C}$ in 24h (except special order).

2.2 The height of installation place should be not higher than 2000m.

2.3 The relative humidity in installation place should be not more than 50% while at highest temperature of $+40^{\circ}\text{C}$, Much higher relative humidity under much lower temperature. The average lowest temperature should be not more than $+25^{\circ}\text{C}$ in most humid month and the maximum relative humidity of this month should be not more than 90%. It's considered that condensation will be produced due to temperature change.

2.4 The pollution is Grade III.

2.5. Main circuit of circuit breaker, coil of under-voltage release and primary coil of power transformer should be installed in IV, other auxiliary circuit and control circuit should be installed in III.

2.6 The circuit breaker should be installed in accordance with the requirements of instruction manual and its vertical slope should not exceed 5° .

3. Technical data and performance

3.1 Basic parameter of circuit breaker (shown in Table 1)

Table 1 Basic parameter

Type	Shell grade current (A)	Rated current I _n	Rated voltage U _e (V)	Rated insulation voltage U _i (V)	Breaking ability of rated limited short circuit I _{cu} (kA)		Breaking ability of rated operating short circuit I _{cs} (kA)		Rated short time withstand current I _{cw} (kA)		Arcover distance (mm)	Power (W)
					400V	660V	400V	660V	400V	660V		
YCW3-1600	1600	200-1600	AC660 AC400	1000	400V	660V	400V	660V	400V	660V	0	360
YCW3-2000	2000	630-2000			65	50	55	42	50	42		
YCW3-2500	2500	630-2500			80	65	65	50	65	50		
YCW3-3200	3200	2000-3200			100	70	80	70	80	70		
YCW3-4000	4000	2500-4000			100	85	85	70	80	70		
YCW3-6300	6300	4000-6300			120	85	100	85	100	85		
					135	100	135	100	135	100		2000

3.2 Protection performance of intelligent release

3.2.1 Protection character of over-current release

3.2.1.1 The setting value I/I_n and the tolerance of release are shown in Table 2.

3.2.1.2 Inverse definite action character of long-time delay over-current protection is shown in Table 3, its inverse curve complies with I²t = (1.5I_{rl})²t.

3.2.1.3 Characters of short-time delay over-current protection

The protection character of this release is inverse at low current and its inverse curve complies with I²t = (8I_{rl})²t, t is short time delay setting; while the overload current is more than 8I_{rl}, it should convert into definite time lag and its character is shown in Table 4.

Table 2 Release current setting and tolerance

Long-time delay		Short-time delay		Instantaneous		Grounding failure	
I _{r1}	Tolerance	I _{r2}	Tolerance	I _{r3}	Tolerance	I _{r4}	Tolerance
(0.4~1) I _n	±10%	(0.4~15) I _n	±10%	1I _n ~100kA +OFF	±15%	(0.2~0.8)I _n (Max1200A) (Min160A)	±10%

Note: 1. while of three sections protection, the setting value should not be across.
 2. Except additional provision in the contract, the current setting value of Ex-factory is I_{r1}=I_n, I_{r2}=8I_n, I_{r3}=12I_n and I_{r4}=0.8I_n
 3. YCW3-1000 I_{r3}=I_n-30 YCW3-2000 I_{r3}=I_n-50kA. YCW3-3200 I_{r3}=I_n-75kA YCW3-6300 I_{r3}=I_n-100kA

Table 3 Characters of short-time delay inverse action

Current	Time						
1.05I _{rl}	>2h no action						
1.3I _{rl}	<2h action						
1.5I _{rl}	Setting time (s)	15	30	60	120	240	480
2.0I _{rl}	Action time (s)	8.4	16.9	33.7	67.5	135	270

Note: 1. time tolerance of action is ±15%. 2. Except additional provision in the contract, the current setting value t1 of Ex-factory is 120s.

Table 4 Characters of short-time delay action

Current	Time					
I ≥ I _{r2} , I ≤ 8I _{rl}	Inverse		I ² t=(8I _{rl}) ² t ₂			
I ≥ I _{r2} , I > 8I _{rl}	definite time lag	Setting time (s)	0.1	0.2	0.3	0.4
		Action time (s)	0.06	0.14	0.23	0.35

Note: 1. time tolerance of action is ±15%. 2. Except additional provision in the contract, the current setting value t1 of Ex-factory is 120s. 3. In the table, I is practical action current, t₂ is setting time for short-time delay and T₂ is practical action time.

3.2.1.4 The protection character of current release is shown in Table 1.

3.2.1.5 Character of protection action of grounding failure

The grounding failure is divided into two kinds. One is to test neutral point current. When three-phase current is balanced, the neutral current is zero; while three-phase current isn't balanced and the neutral point current is beyond setting current, the intelligent release alarms, after delay time of setting, it sends instructions to enable the circuit breaker breaking or not breaking. The other is to test grounding wire current. When the current is beyond setting value, the intelligent release alarms, after delay tbreaking setting, it sends instructions to the circuit breaker breaking or not breaking. The character of grounding failure protection is definite time lag and its delay characteristics conform to Table 5, and its protection characteristics are shown in Figure 2.

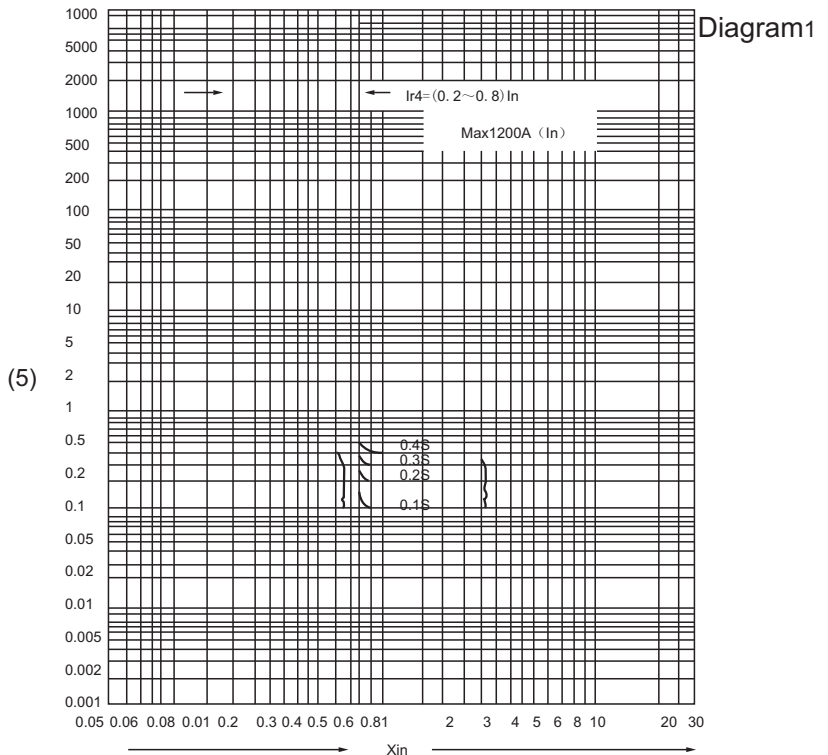
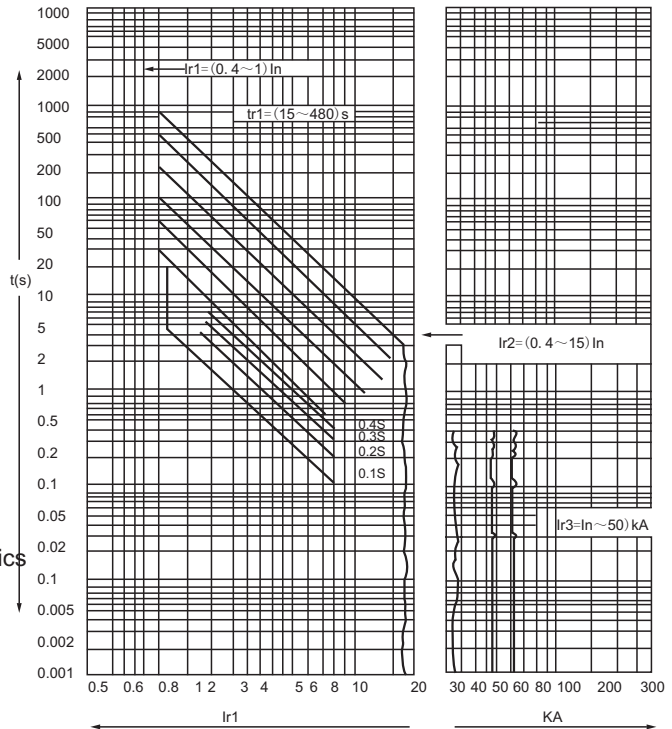

Diagram1

Figure 2

3.2.2 Multi-function performance of intelligent release

3.2.2.1 Ammeter function

Display maximum phase current of major loop on digital pipe. Press select and display corresponding phase current of indication lamp.

3.2.2.2 Voltage function

Display maximum phase voltage of major loop on digital pipe. Press select and display corresponding phase voltage of indication lamp (installation as per requirements).

3.2.2.3 Self-diagnosis function

A) The release has self-diagnosis failure function.

When the computer failure happening, it displays "E" or alarms, meanwhile restart the computer. If the users require, it also can break the circuit breaker.

B) When local environmental temperature is 80°C or inner temperature of shell exceeds 80°C due to the contact heating, it can alarm and break the circuit breaker at low current (when the users require).

3.2.2.4 Setting function

Press $\text{set} + \text{and}$, and randomly regulate the current and the time delay required by the users. After reaching required current or time delay, pressing energy storage again can comply with current setting and time delay of the users. If the current failure happening, it can intermediately carry out this function and protect the current.

3.2.2.5 Testing function

Press $\text{set} + \text{and}$ - to select required current, testing button to conduct release testing. There are two testing buttons. One is no tripping testing button and the other is tripping testing button. The former testing function can be operating when the circuit breaker is connected to electric net. While actual over-current in the net, it can break the testing function to protect over-current.

3.2.2.6 Load monitoring function

Set ILC1 and ILC2 (setting value) range (0.2~1)In. ILC1 is inverse character and its time delay setting value is half of long-time delay setting value. ILC2 has two kinds of time delay. One is inverse character and its time setting value is quarter of long-time delay setting value; the other is definite time and its time delay is 60s. The former is used to break most unimportant load when the current is nearly overload setting value and the latter is used to reduce the current and keep power supply to main circuit and key load circuit after break unimportant load at lower level when the current exceeds ILC1 value. It sends the instruction, switches on cutting-off circuit again and recovers power supply of whole system after time delay when the current is ILC2. The character of loading monitoring is shown in Figure 3 and Figure 4.

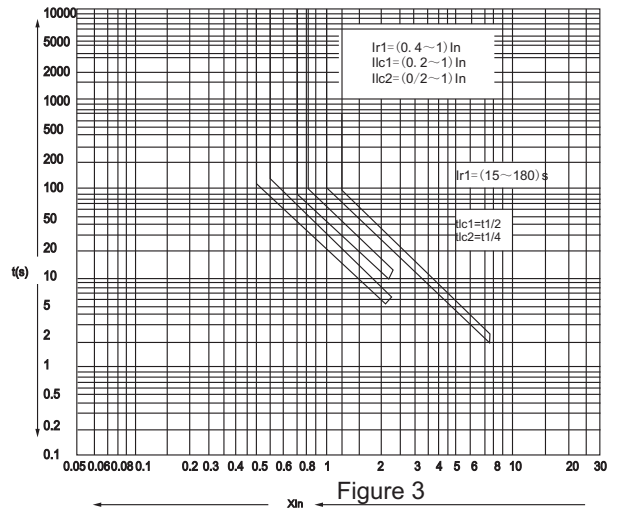

Figure 3

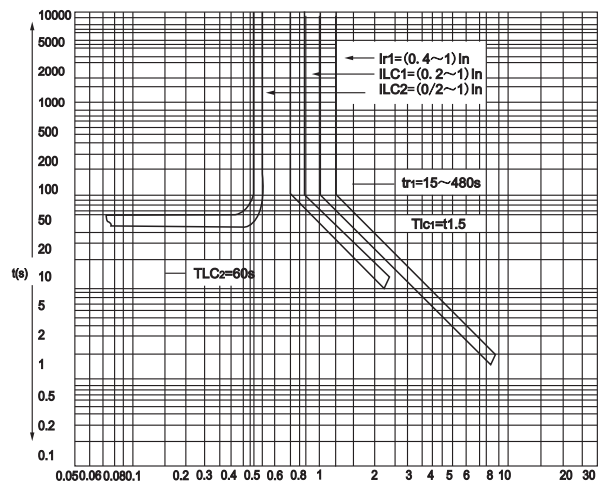

Figure 4

3.2.2.7 Displaying function of release

The release displays the current and the voltage (namely ammeter and voltmeter function) when in operation, and stipulated protection section when failure happening. It locks the failure and displays failure current after break the circuit breaker. While setting, it displays current, time and section type of setting section. If time delay action, the indication lamp flashes during action process and it turns into constant lighting after break the circuit breaker. It displays testing current, time delay testing indication and testing action section while testing.

3.2.2.8 Thermal Simulation Function

Through overload and short-time delay after the release is tripped, it will have the memory function with the characteristics of simulation and bimetallic strip. The discharging of overload energy lasts 30 min, and the short-time delay energy 15 min. In the meantime, if there is anything wrong with the overload or short-time delay, the tripping time will be shortened; the release will be disconnected and the energy will return to zero automatically.

3.2.2.9 Communication Function

In addition to all the functions of the intelligent controller, the release has the function of serial communication interface which constitutes the local network system of Master-Slaver Structure (hereinafter referred to as System), with 1-2 computers as a master station, and several intelligent circuit breakers or other communication interface components as the slave station. The systematic network structure is shown as follows. For the control unit for circuit breaker, the system can achieve the long-range four functions of "remote control ": monitoring for power network parameters and motion parameters, monitoring for the current running state of the intelligent breaker, the adjustment and download for different kinds of protective value limit parameters, control for the closing/opening operation of intelligent breaker. The System is suitable for all kinds of power distribution systems and power plants, medium-small transformer stations, and the construction and restoring of power distribution monitoring devices for the mining industry and buildings. The connection diagram of special communications protocol interfaces is shown below:

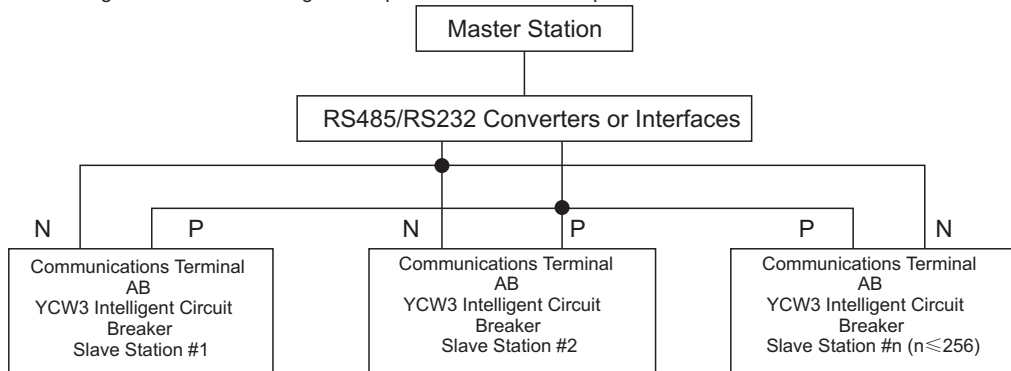

The connection diagram of the DP-protocol breaker is shown as follows:

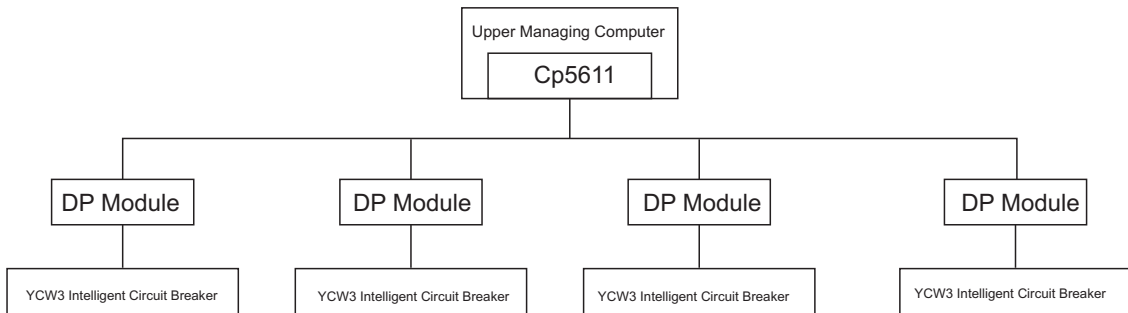

1. System includes

a) Hard structure of data communication network system

△The intelligent circuit breaker has standard RS485 communication interfaces; the lead-out for the number 10 to 11 out-going lines of the breaker;

△Communication media of system connection; class A shielded twisted pair wire.

b) Main features of the network

△Transmission mode of bidirectional serial data: The product can provide a wide range of communications protocols, " Data Transmission Communications Statute V1.0 of Low-voltage Apparatus,"PROFIBUS-DP, MODEBU, etc.

△Strict master-slave mode, namely the sender and controller of the master station communication; the slave station can merely communicate with the master station, and can not directly communicate with other slave stations.

△The communication baud rate is 9600 bit / s;the communications distance is 1.2 km; in view of PROFIBUS-DP, typical application of the communication baud rate can reach 187.5 bit / s.

C) Monitoring software

YSS 2000 configuration software can achieve the goal of configuration applications of the necessary monitoring management software in accordance with different engineering requirements. For the intelligent circuit breaker, the operational monitoring and functions of day-to-day management can be achieved.

2. Function of communications system

a) Remote control

Remote control means that the computer of the master station controls the energy storage, closing and disconnection of the circuit breaker for each slave station of the system. The operator can choose from the system interface.

For the corresponding object, use the mouse to click the remote control button, and then the system will present the current operation state of the corresponding object. After the operator has input the operation password, by means of remote control, the directive "closing" or "disconnection" can be sent out. The System will send the directive to the slave station of the corresponding circuit breaker. After receiving the directive, the slave station will conduct the operations such as disconnection, closing, and energy storage in accordance with established time sequencing, reporting the results of remote control to the master station.

b) Remote adjustment

Remote adjustment means that the computer of the master station sets the protection setting value of each slave station. In the computer of the master station are stored all the protection setting value tables. The operator chooses the corresponding objects from the system interface. By using the mouse to click the remote-control button, the system will provide all the current setups of the protection setting value and the protection setting value tables for the corresponding objects. After the operator has input the password, the required parameters can be selected from the parameter table. And click the corresponding button, then the master station will download the parameters and send them to the corresponding slave stations, reporting the results of remote adjustment. After receiving instructions, the slave station will revise its own protection values.

c) Telemetering

The telemetering means that the master station computer gives the real-time monitoring for the electrical network parameters of each slave station. The operational parameters which the communication station report to the upward computer are shown as follows: Each sub-station's real-time current values of phase L1, L2, L3, and N; real-time voltage values for UAB, UBC, UCA and so on.

△ Fault recording can record the fault parameters

when the faults happen, the current values of phase L1, L2, L3 and N, the voltage values of UAB, UBC and UCA, the fault type, the fault operating time, and the fault mentioned herein will be recorded in the database.

△By means of the bar graph and the absolute value, the computer can display the current real-time electric current and voltage for each sub-station, and can show the running state of each node point with real-time curves.

d) Remote Communication

Remote communication indicates that the master station computer can check the model number of the slave station, the closed or disconnected state of the slave station, the protection setting values, the operation of slave stations and fault information. The parameters for the breaker of the slave station submitted to the upward computers include: switch state (closing /disconnection), fault information, alarm information, various protection setting values and so on.

3.Other Functions for Communication System

Apart from the four remote-control functions, the System also has various management functions: Accident alarm (information screen, screen movement, events Printing, dialing for accidents, audible alarm), incident records, maintenance listing, duty-shifting management, load trend analysis and printing of various report forms.

3.3 Rated voltage and consumption power of breaker control circuit are shown in table 5

Table 5 Rated voltage and consumption power of control circuit

Items	Consumption Power			
	AC230V	AC400V	DC110V	DC220V
Shunt Release Us	500VA	500VA	500W	500W
Under-voltage Release Ue	85VA	85VA	—	—
Exoergic (closing) Electromagnet	500VA	500VA	500W	500W
Electric Operating Mechanism	$I_n \leq 2000A$	85VA	85VA	85W
	$2000A < I_n \leq 3200A$	110VA	110VA	110W
	$3200A < I_n \leq 6300A$	150VA	150VA	150W
Supply Voltage of Intelligent Controller	AC230V、AC400V、DC110、DC220V			
Note 1: The shunt release (from 70% to 110% Us) can be reliable to guarantee the disconnection; the motor operation (from 85% to 110% Us) can reliably finish the energy storage; the closing electromagnet should guarantee the closing of the breaker between 85% and 110% Us. 2: The under-voltage release (from 70% to 35% Ue) disconnects the circuit breaker; when less than 35% Ue, the closing of the circuit breakers should be prevented; when equal to or more than 85% Ue, it should guarantee the closing of the circuit breaker. For the under-voltage release with time-delay function, the delay time is adjustable from 1s to 10s. Accuracy is $\pm 10\%$				

3.4 The number of cyclic operation for circuit breaker serviceability is shown in the table 6

Table 6 Circulation times of circuit breaker operation

Rated Current of Shell Grade	Turn-on Operation Times	Cold Operation Times	Total Cycle Number of Operation	Operation Cycle/Hour
1600A、2000A、2500A	1000	4000	5000	60
3200A、4000A	500	2500	3000	20
6300A	500	1500	2000	10

4 Structure description

The fixed circuit breaker is mainly composed of the contact system, intelligent release, manually-operated mechanism, electric operating mechanism, mounting panel;

The drawer circuit breaker is mainly composed of the contact system, intelligent release, manually-operated mechanism, electric operating mechanism, drawer seat;

The circuit breaker takes the three-dimensional arrangement form, which is compact and small. The contact system is sealed in the insulation base, each phase of the contact system is separated by using the insulating board, forming cabinets, while the intelligent release, manually-operated mechanism and electric operating mechanism are shown in the front in turn, forming separate units; if a unit is broken, the whole unit can be replaced with a new one. (Shown in figure 5).

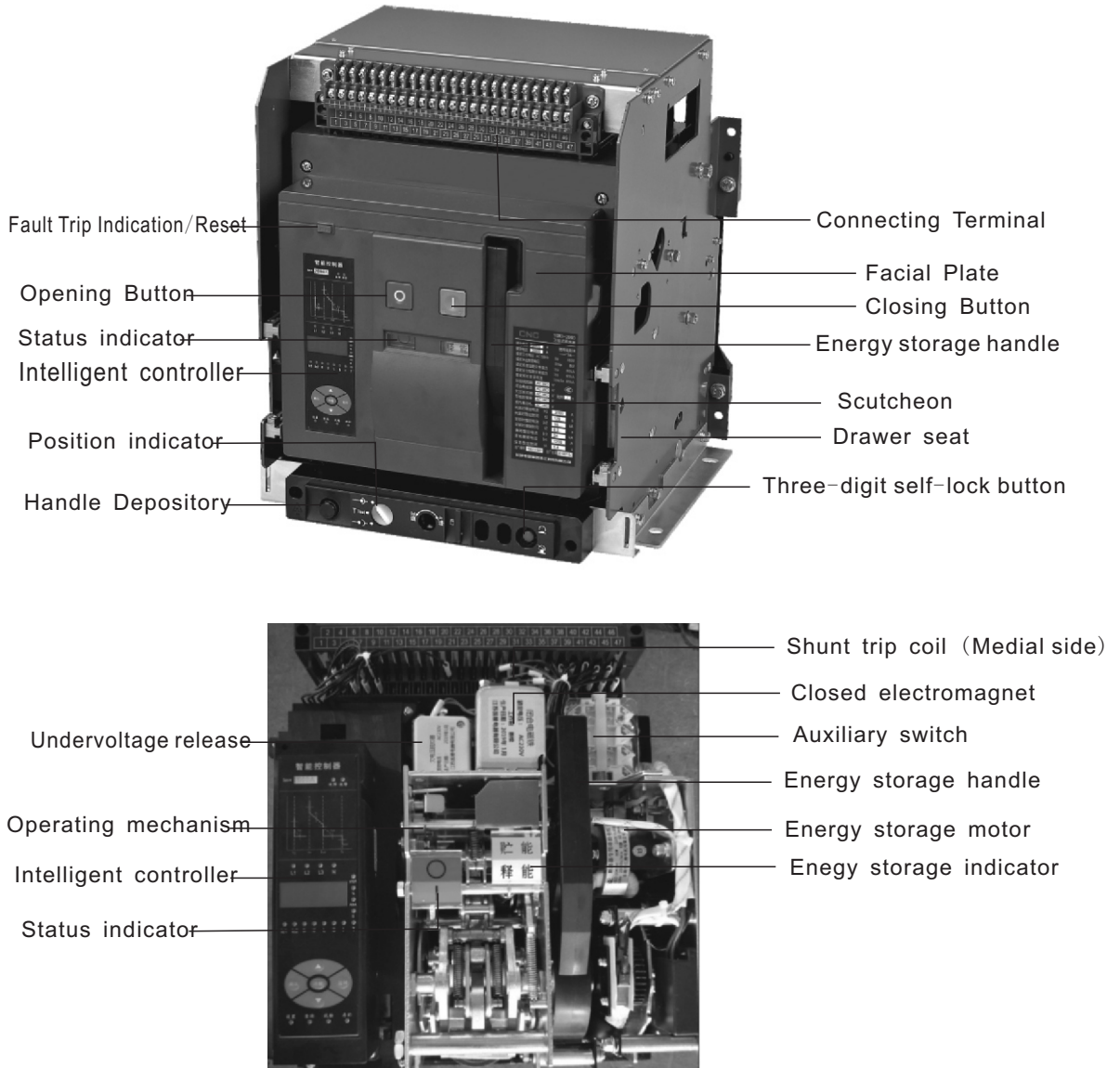

YCW3 Series Intelligent Universal Circuit Breaker

4.1 Contact system (shown in figure 6)

Each phase of the contact system is installed in a cabinet formed by the insulation board, with the arc chamber above the cabinet. by connecting the link bar with the main shaft outside the insulation board, the contact system thereby achieves the tasks for closing and disconnection. In order to reduce electrical repulsion, each phase of the contact system take the parallel connection form of the 10-gear contact, and the 10-gear contact is installed on a contact support. N pole takes the 6-gear contact. One end of the contact plate connects with the bus bar through soft connection. When the circuit breaker is closed, after the moving contact connects with the static contact, the main shaft will drive the link bar to continue rotation by compressing the spring at a certain angle so as to create some contact pressure, ensuring reliable closing of the circuit breaker.

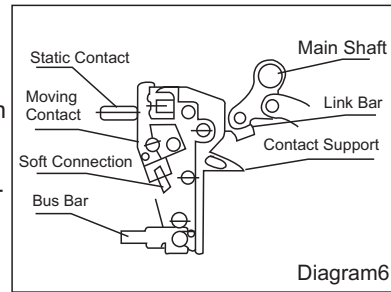

Diagram6

4.2. Operating Mechanism (shown in figure 7)

The circuit breaker has manual and electric operation modes and use the spring to store energy (with the energy pre-storing); the closing speed has nothing to do with electric or manual operation speed. The breaker uses the cam to compress a group of springs to achieve the goal of energy storage with free tripping function. There are three operating positions for the circuit breaker.

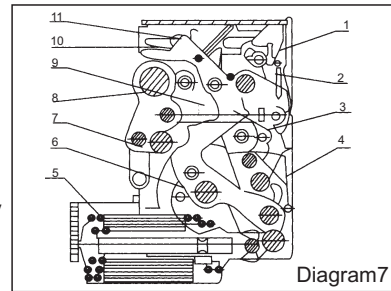

Diagram7

a) Energy storage (see figure 8): Through electric operation or manual operation, the cam is driven to rotate, supporting the lever of energy storage. During the rotation, the spring of energy storage is constantly compressed. When the cam rotates to a certain angle, the fixed axis above it is exactly pressed on the lever 1; the other end of the lever 1 is on the half shaft of the exoergic release. On the other hand, electrical operation or manual operation drives the link bar 1 to rotate, with the link bar 1 supporting lever 2, and make the lever 2 rotate to the re-trip position; at last the release half shaft rotates to the re-trip angle and the lever 2 rotates to the re-trip position. Then the energy storage ends, ready for the closing of the circuit breaker.

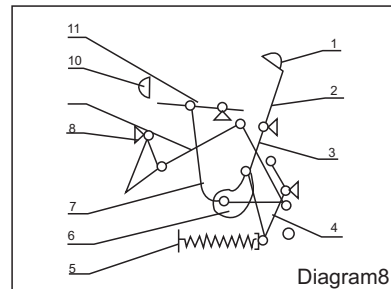

Diagram8

1-Half Shaft of Exoergic Release
4-Energy Storing Lever
7-Link Bar 1
10-Half Shaft of Breaking Release

b) Closing (see figure 9): Press button "1" or switch on electromagnet to make the main shaft of exoergic release rotate counterclockwise and keep the energy storing lever rotating counterclockwise. Then the axle pin of energy storing lever would hit hard on the link bar 2 to rotate it, so that the circuit breaker would be closed.

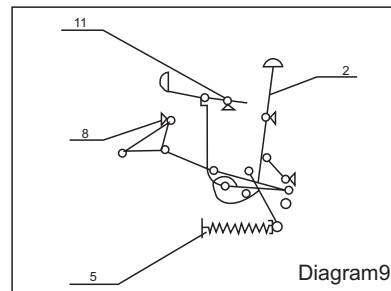

Diagram9

2-Lever I
5-Energy Storing Spring
8-Main Shaft
11-Lever 2

c) Disconnection (see figure 10): press "0" button or through the over-current, under-voltage, shunt signal, experimental signal of the intelligent release, the half shaft 10 of breaking release rotates clockwise; the lever 2 is tripped and the pressure on the link bar 1 disappears. The link bar 1, 2, 3 are combined for the four-bar to form the five-bar, with the link bar 1 in a free state. Under the contact counterforce and the reset ejection, the circuit breaker is quickly disconnected.

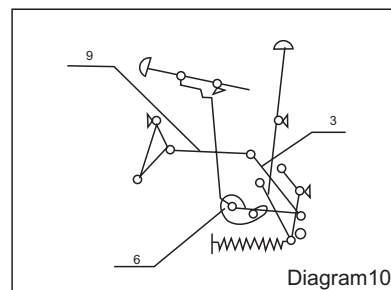

Diagram10

3-Link Bar 2
6-Cam
9-Link Bar 3

4.3 Intelligent release

The composition of the release is shown in the following relation diagram (see Figure 11)

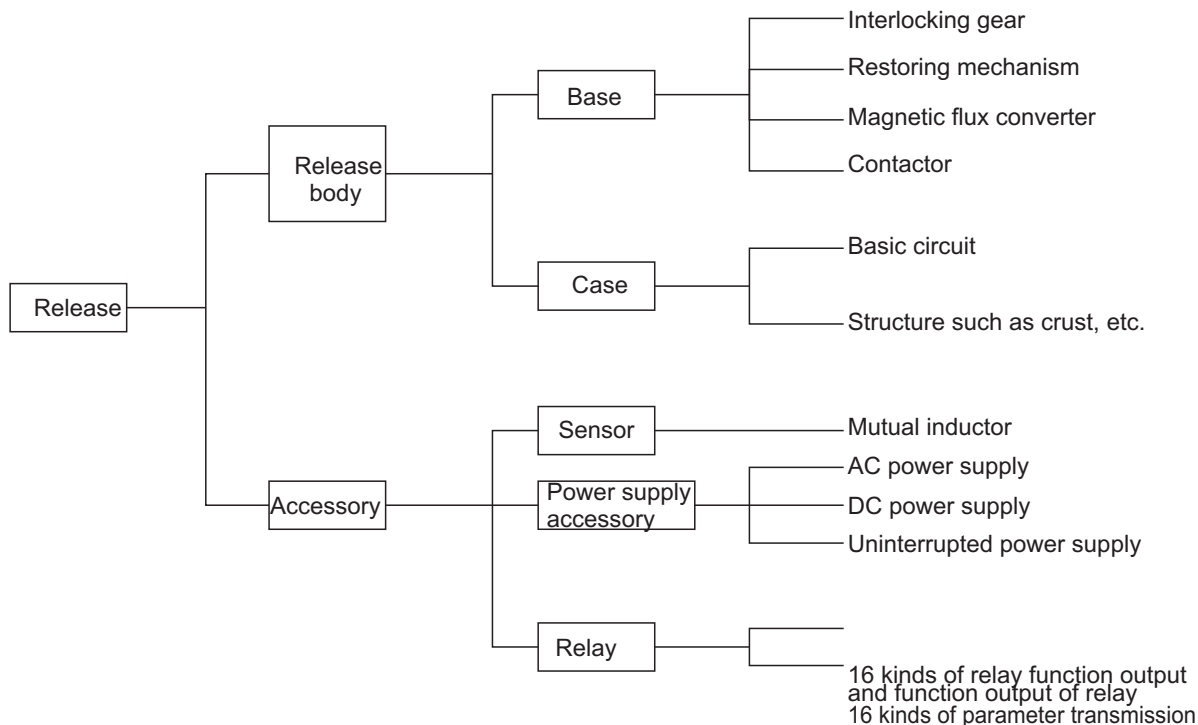

Figure 11

4.3.1 Base

The base consists of the following parts, being the appliance of function Execution

- a. Interlocking gear: Being the Executive element of the release as well as the release level of action drive of magnetic flux converter, the gear breaks the breaker and resets
- b. Restoring mechanism: Reset magnetic flux converter immediately after the breaking of the main contact by the action of magnetic flux converter

- c. Magnetic flux converter: Produce a magnetic field by receiving the electric current from the circuit of release to change the direction of magnetic line of force and drive the release level through moving iron core and under the action of reaction spring.
- d. Contact group: Determine the position of division and joint of the contact according to state of the contact of breaker.

4.3.2 Sensor

The sensor is installed on the bus of the main loop of the breaker and designed to provide energy and signor for operation of the release. Different from the traditional sensor, the sensor consists of a rapid-saturable current transformer providing the energy for normal operation of release and a major air-core transformer providing the current change of circuit, the size of secondary current of the air-core transformer varies directly with that of main loop. The two transformers are simultaneously installed into the same round plastic box.

4.3.3 Accessories of power supply

The accessories are divided into the following types: the accessory of the power supply is derived from the voltage of the major loop and designed to display and memorize the working state in the case of main circuit broken by breaker of very small current, the accessories installed on the drawer holder are classified into many kinds of power supply such as Ac, Dc and uninterrupted so as to ensure the energy source of power supply for the computer and relay accessory.

4.3.4 Relay

Based on the release function, the accessories of expansion relay are classified into two kinds: One is the output of relay contact providing the indications of overloading and short-circuit action, and the indication and instruction involving action of load monitoring as well as sixteen different combinations of failure indication, the other is the relay output providing indicators and actions characterized different combinations for users as well as remote transmission of various parameters implemented by computer control.

4.4 Other releases

Under-voltage release (see Figure 12)

Shunt release (see Figure 12)

Releases able to cut off circuit-breaker from a long distance.

Closed electromagnet (see Figure 12)

The breaker is at the cutting-off position after energy storage, and able to close circuit-breaker by electrifying the electromagnet.

Drawer-type circuit-breaker consists of circuit-breaker body and drawer holder, the guide rail inside the drawer holder is able to be drawn in and out and got to the main loop by the plug connection between the bus on the breaker body and bridge plug on the drawer holder.

There are three places of work on drawer-type circuit-breaker: namely, positions of connection, test and separation, changing between the positions are realized by turning the handle. Directions involving the three positions are displayed via the pointer on the bottom beam of the drawer holder. While being in the place of connection, the main and secondary loops are all connected. Being in the place of test, the main loop is broken, and insulated by Insulating Separator, while the secondary loop is collected, in this case, some necessary action experiments can be carried out, while being in the place of separation, the main and secondary loops are all broken. Owing to the machinery interlocking device in the drawer-type breaker, only in the place of connection or test, can the circuit-breaker close the device, the circuit-breaker in the middle place of experiment and connection is not able to be closed.

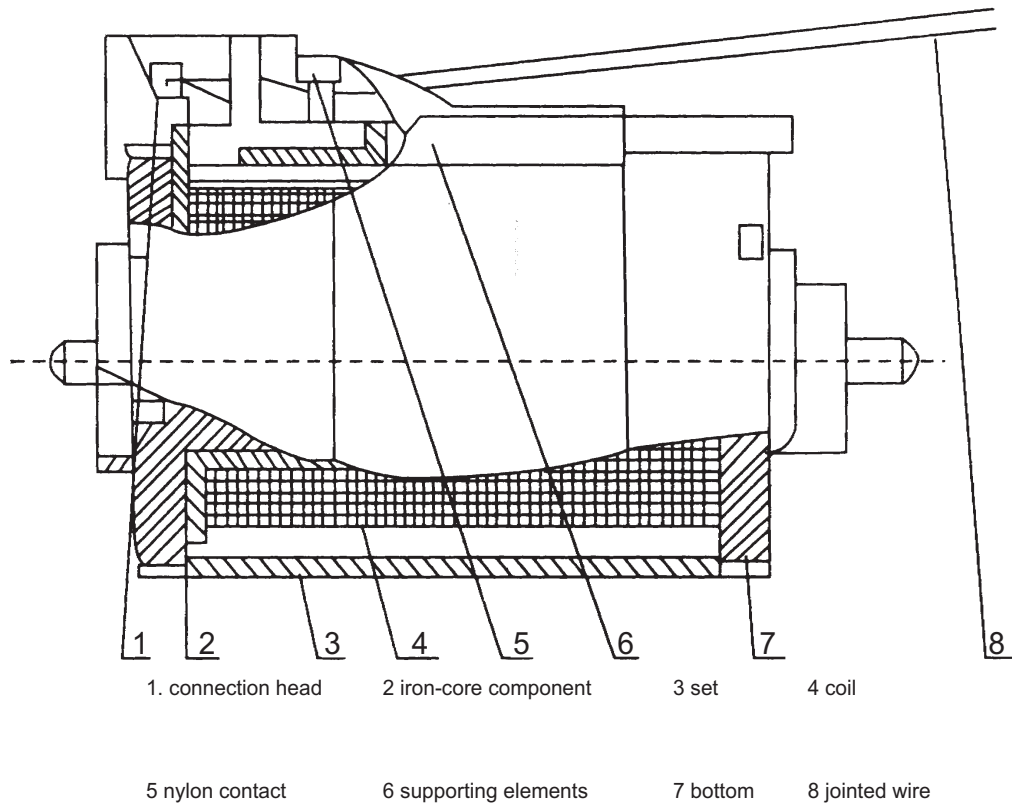

Figure 12

YCW3-1600A Secondary wiring diagram (the controller is L type or M type with additional function) (the contact of the auxiliary switch is four-group conversion)(Standard type)

5 Wiring diagram

#1, #2 AC working power supply input (input from DC modules of U1 and U2 in the case of the direct current)

#12 Output of overload pre-alarming signal

#16 Grounding tripping or alarm signal output (or signal of electric leakage)

#17 Output of disposable load 1 signal } possessed by only 2M type

#18 Output of disposable load 2 signal

#19 Signal output common

#20 Output of self-diagnostic alarming signal

#210 Output of CR fault tripping signal

#22 A phase of power supply signal } possessed by 2M type in the case of direct input from the main loop

#23 B phase of power supply signal

#24 C phase of power supply signal

#25, 26 Input of neutrality-pole or ground current transformer.

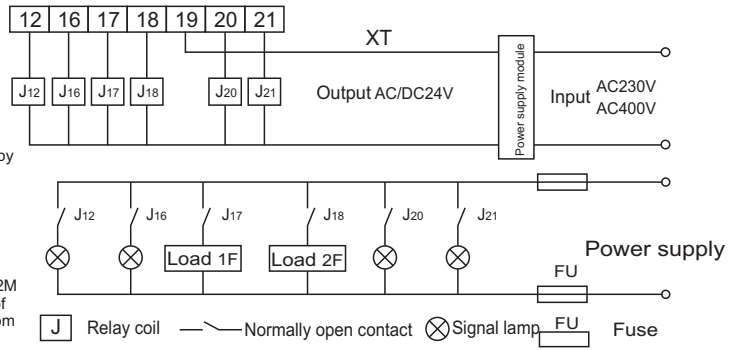

Wiring diagram of relay for the additional functions of relay

- 1) The output of controller signal drives the output of joint action signal through the terminals of 12, 16, 17, 18, 20 and 21
- 2) Module of power supply (the user needs to specify the voltage in the goods-ordering specification) is provided by the manufacturer, which can be inserted into the standard guide rail with the base of relay, and installed at a proper place in the switch cabinet
- 3) Types of relay: HH62P, Ac/Dc24v, provided by users for themselves
- 4) The users can freely choose to collect terminals of J12, J16, J17, J18, J20, J21 based on their practical needs

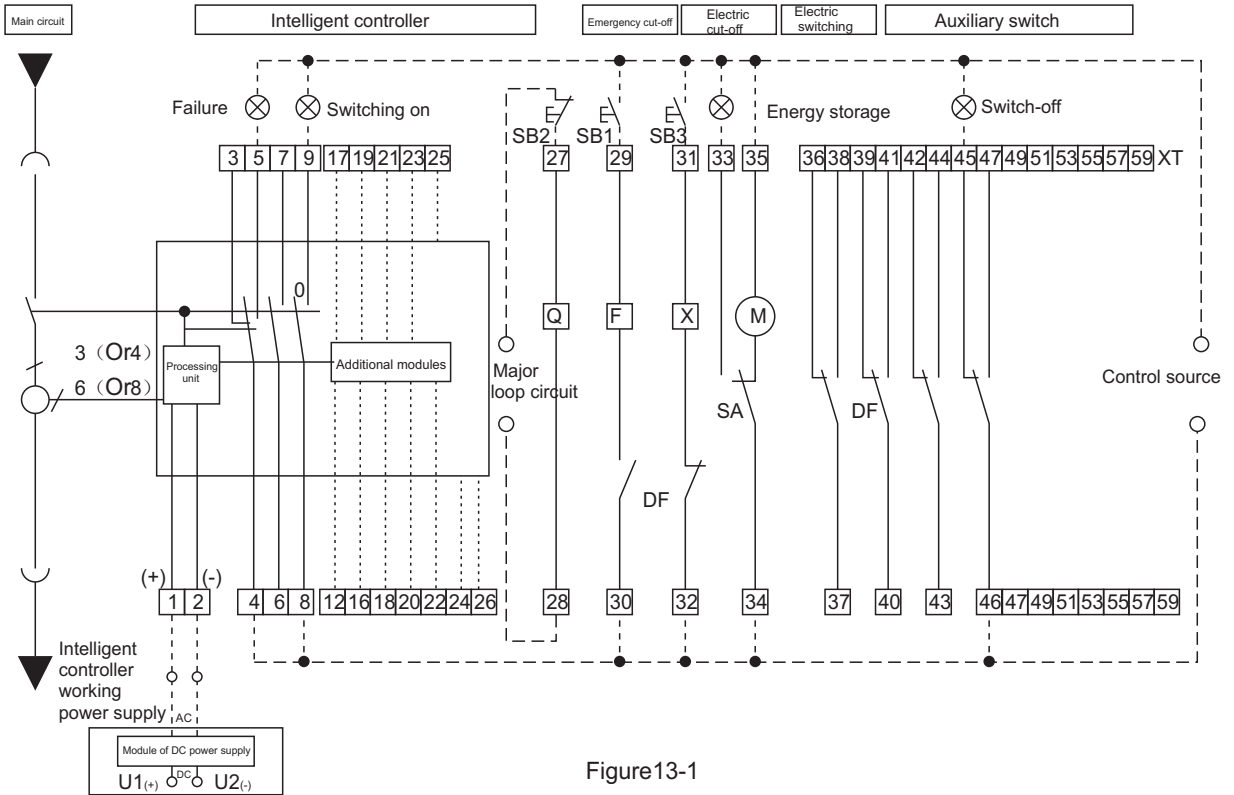

Figure13-1

Notes: 1. All wiring in dashed area is completed by customer

2. 6 & 7 terminals: if the current transformer is applicable for the external neutral wiring, access 6 & 7 terminals.

3. When the control power voltage of F, X & M intelligent controllers are different requiring introducing different power supplies, it is not recommended to introduce back to the main circuit directly to provide high reliability to power supply.

4. Terminal #35 can access the power directly (automatic pre-energy storing), and be serially connected the normally open switch and power finally (energy storing of manual control).

5. Additional accessories are provided by the customer

6. Required by the customer, terminals #8-#9 can output normally closed contact (comm. provided products is in normally opened)

7. * If the intelligent controller applies DC work power, DC power modular is needed to be added while the terminals #1 and 2 could not access directly to the AC power, and the secondary circuit

SBI shunt excitation button (provided by users for themselves)	X switching-on electromagnet	DF auxiliary contact	Q under-voltage release or under-voltage time delay release
SB2 under-voltage button (provided by users for themselves)	M energy-storage electric machine	F shunt release	O normally open contact (3A/AC400V)
SB3 switching-on button (provided by users for themselves)	XT connecting terminal	Sensitive switch of SA electric machine	⊗ signal lamp (provided by users for themselves) FU fuse

YCW3-2000~6300A Secondary wiring diagram (the controller is L type or M type with additional function) (the contact of the auxiliary switch is four-group conversion)(Standard type)

5 Wiring diagram

- #1, #2 AC working power supply input (input from DC modules of U1 and U2 in the case of the direct current)
- #12 Output of overload pre-alariming signal
- #16 Grounding tripping or alarm signal output (or signal of electric leakage)
- #17 Output of disposable load 1 signal } possessed by
- #18 Output of disposable load 2 signal } only 2M type
- #19 Signal output common
- #20 Output of self-diagnostic alarming signal
- #210 Output of CR fault tripping signal
- #22 A phase of power supply signal } possessed by 2M
- #23 B phase of power supply signal } type in the case of
- #24 C phase of power supply signal } direct input from
- #25, 26 Input of neutrality-pole or ground current transformer.

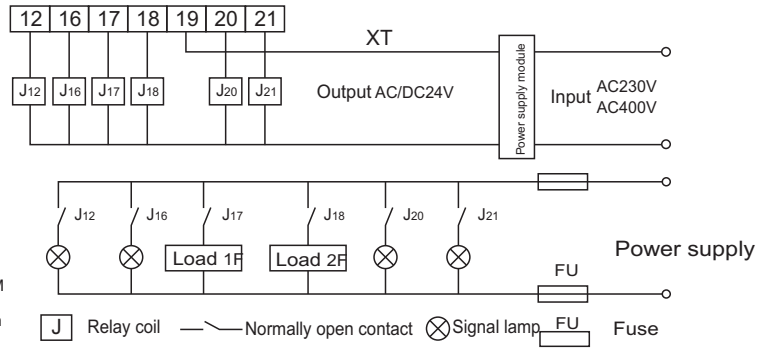

Wiring diagram of relay for the additional functions of relay

- 1) The output of controller signal drives the output of joint action signal through the terminals of 12, 16, 17, 18, 20 and 21
- 2) Module of power supply (the user needs to specify the voltage in the goods-ordering specification) is provided by the manufactory, which can be inserted into the standard guide rail with the base of relay, and installed at a proper place in the switch cabinet
- 3) Types of relay: HH62P, Ac/Dc24v, provided by users for themselves
- 4) The users can freely choose to collect terminals of J12, J16, J17, J18, J20, J21 based on their practical needs

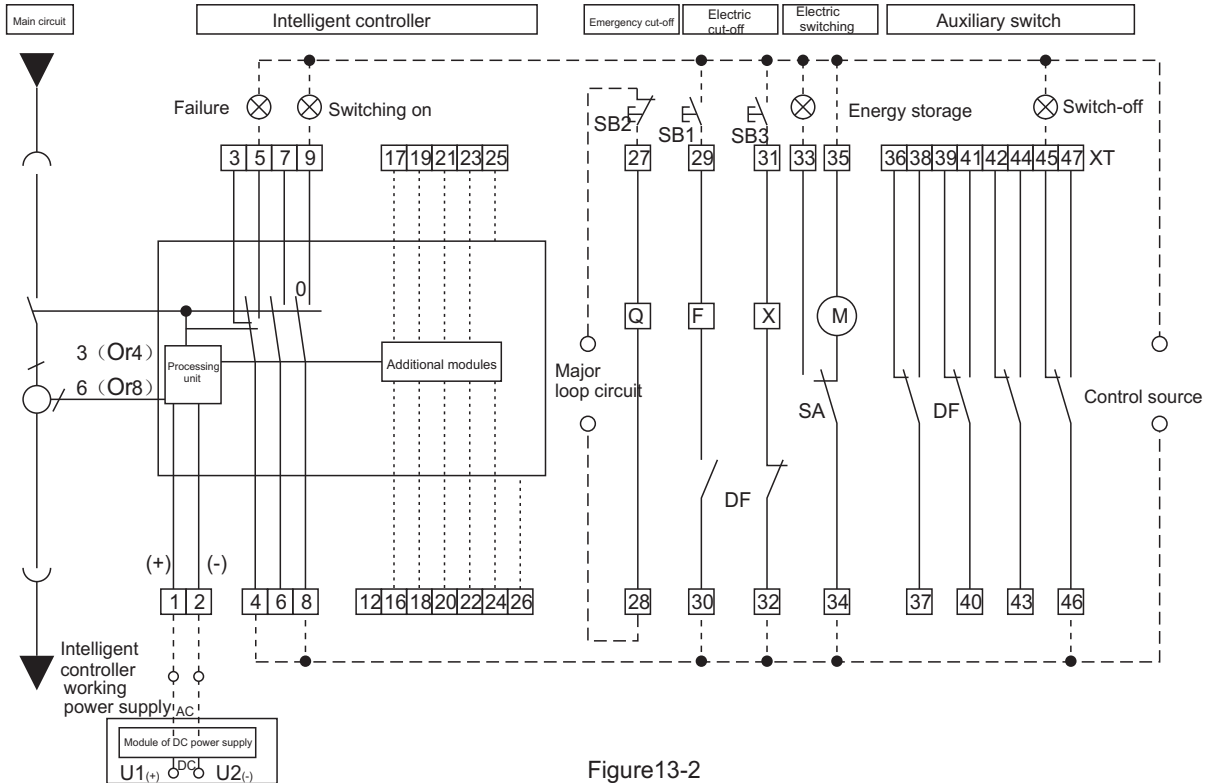

Figure 13-2

- Notes: 1. All wiring in dashed area is completed by customer
 2. 6 & 7 terminals: if the current transformer is applicable for the external neutral wiring, access 6 & 7 terminals.
 3. When the control power voltage of F, X & M intelligent controllers are different requiring introducing different power supplies, it is not recommended to introduce back to the main circuit directly to provide high reliability to power supply.
 4. Terminal #35 can access the power directly (automatic pre-energy storing), and be serially connected the normally open switch and power finally (energy storing of manual control).
 5. Additional accessories are provided by the customer
 6. Required by the customer, terminals #8-#9 can output normally closed contact (comm. provided products is in normally opened)
 7. * If the intelligent controller applies DC work power, DC power modular is needed to be added while the terminals #1 and 2 could not access directly to the AC power, and the secondary circuit

- | | | | |
|--|-----------------------------------|---|---|
| SBI shunt excitation button (provided by users for themselves) | X switching-on electromagnet | DF auxiliary contact | Q under-voltage release or under-voltage time delay release |
| SB2 under-voltage button (provided by users for themselves) | M energy-storage electric machine | F shunt release | O normally open contact (3A/AC400V) |
| SB3 switching-on button (provided by users for themselves) | XT connecting terminal | Sensitive switch of SA electric machine | ⊗ signal lamp (provided by users for themselves) FU fuse |

YCW3-2000-6300 Connection diagram of secondary loop of the relay of L or M type intelligent controller (the contact of the auxiliary switch is characterized by four-normally open and four-normally close)

Intelligent controller & Other Wirings

- #1, #2 AC working power supply input (input from DC modules of U1 and U2 in the case of the direct current)
 - #12 Output of overload pre-alarming signal
 - #13 Output of communication remote-control shunt tripping
 - #14 Output of communication remote-control switching on
 - #15 Output of communication remote-control energy storage
 - #16 Grounding tripping or alarm signal output (or electric leakage signal)
 - #17 Output of disposable load 1 signal, possessed by only 2M type
 - #18 Output of disposable load 2 signal
 - #19 Signal output common
 - #20 Output of self-diagnostic alarming signal
 - #21 N phase of power supply signal
 - #22 A phase of power supply signal
 - #23 B phase of power supply signal
 - #24 C phase of power supply signal
 - #25, #26 Input of neutrality-pole or ground current transformer
- } is directly inputted from the major loop

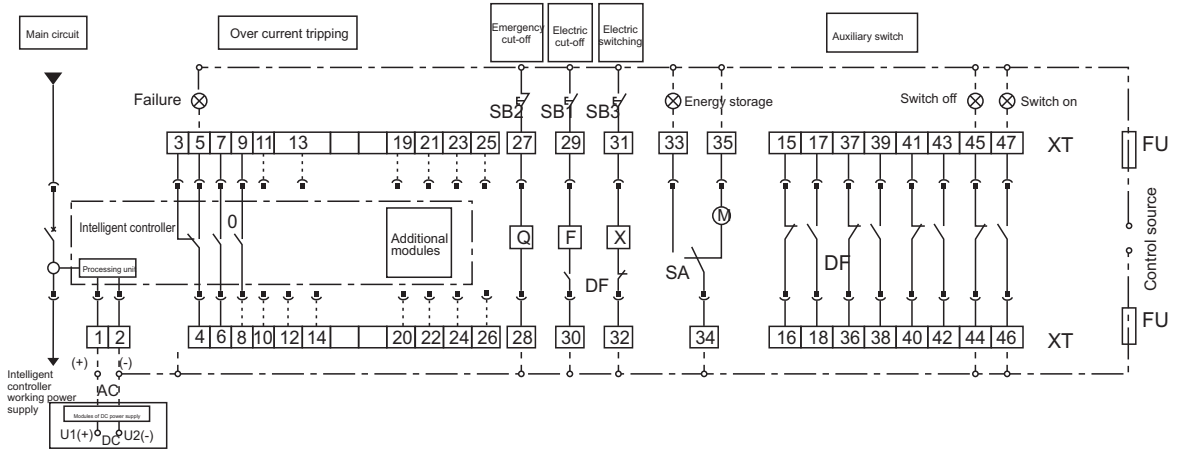

Figure 13-3

Notes:

1. All wiring in dashed area is completed by customer
2. 6 & 7 terminals: if the current transformer is applicable for the external neutral wiring, access 6 & 7 terminals.
3. When the control power voltage of F, X & M intelligent controllers are different requiring introducing different power supplies, it is not recommended to introduce back to the main circuit directly to provide high reliability to power supply.
4. Terminal #35 can access the power directly (automatic pre-energy storing), and be serially connected the normally open switch and power finally (energy storing of manual control).
5. Additional accessories are provided by the customer
6. Required by the customer, terminals #8-#9 can output normally closed contact (comm. provided products is in normally opened)
7. * If the intelligent controller applies DC work power, DC power modular is needed to be added while the terminals #1 and 2 could not access directly to the AC power, and the secondary circuit

SB1 shunt excitation button (provided by users for themselves)
 SB2 under-voltage button (provided by users for themselves)
 SB3 switching-on button (provided by users for themselves)

X switching-on electromagnet
 M energy-storage electric machine
 XT connecting terminal

DF auxiliary contact
 Fshunt release
 Sensitive switch of SA electric machine

Q under-voltage release or under-voltage time delay release
 O normally open contact (3A/AC400V)
 ⊗ signal lamp (provided by users for themselves)..FU fuse

YCW3-2000~6300 Secondary Circuit Wiring for Breaker of L or M Intelligent Controller
(Auxiliary switch contact with 6-NO & 2-NC)

Intelligent controller & Other Wirings

- #1 & #2 AC work power input (if DC is applicable, input through DC modular U1 & U2)
- #12 Overload pre-alarm signal output
- #16 Ground release or alarm signal output (or electric leakage alarm signal)
- #17 Unload signal output 1 } 2M model only
- #18 Unload signal output 2
- #19 Signal output bus
- #20 Self-diagnostic alarm signal output
- #21 N phase of power supply signal
- #22 A phase of power signal
- #23 B phase of power signal } is directly input through main circuit
- #24 C phase of power signal }

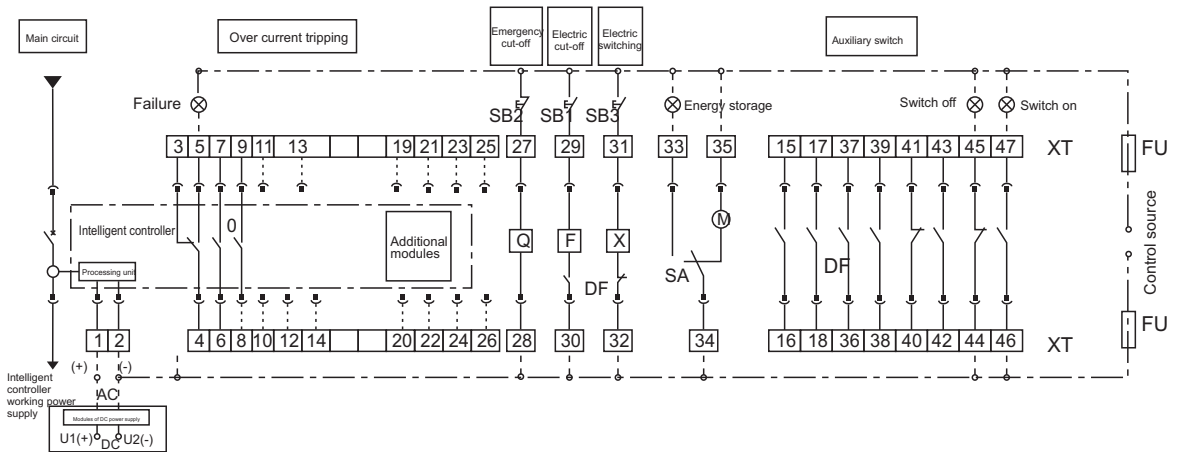

Diagram 13-4

Notes:

1. All wiring in dashed area is completed by customer
2. 6 & 7 terminals: if the current transformer is applicable for the external neutral wiring, access 6 & 7 terminals.
3. When the control power voltage of F, X & M intelligent controllers are different requiring introducing different power supplies, it is not recommended to introduce back to the main circuit directly to provide high reliability to power supply.
4. Terminal #35 can access the power directly (automatic pre-energy storing), and be serially connected the normally open switch and power finally (energy storing of manual control).
5. Additional accessories are provided by the customer
6. Required by the customer, terminals #8-#9 can output normally closed contact (comm. provided products is in normally opened)
7. * If the intelligent controller applies DC work power, DC power modular is needed to be added while the terminals #1 and 2 could not access directly to the AC power, and the secondary circuit

SBI shunt excitation button (provided by users for themselves) X switching-on electromagnet
 SB2 under-voltage button (provided by users for themselves) M energy-storage electric machine
 SB3 switching-on button (provided by users for themselves) XT connecting terminal

DF auxiliary contact Q under-voltage release or under-voltage time delay release
 Fshunt release O normally open contact (3A/Ac400V)
 Sensitive switch of SA electric machine ⊗ signal lamp (provided by users for themselves)..FU fuse

YCW3-2000~6300 Secondary Circuit Wiring for Breaker of L or M Intelligent Controller
(Auxiliary switch contact with 3-NO & 3-NC)

Intelligent controller & Other Wirings

- #1 & #2 AC work power input (if DC is applicable, inputs through DC modular U1 & U2)
- #12 Overload pre-alarm signal output
- #16 Grounded release or alarm signal output (or electric leakage alarm signal)
- #17 Unload signal output 1 is only applied for the 2M model
- #18 Unload signal output 2
- #19 Signal output bus
- #20 Self-diagnostic alarm signal output
- #21 OCR fault trip signal output
- #22 A phase of power signal
- #23 B phase of power signal } is directly input through main circuit
- #24 C phase of power signal }
- #25 & #26 External neutral or grounding current transformer input

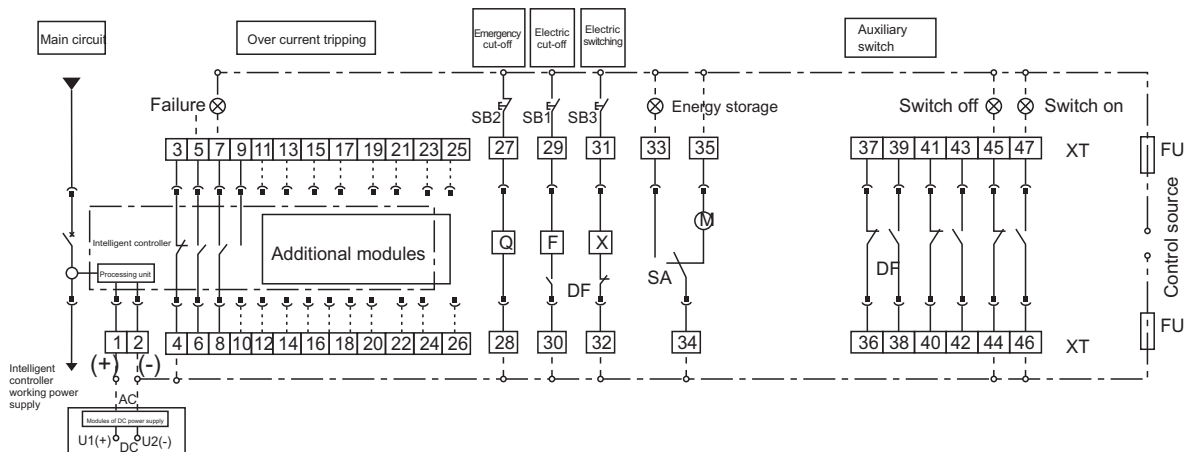

Diagram 13-5

Notes:

1. All wiring in dashed area is completed by customer
2. 6 & 7 terminals: if the current transformer is applicable for the external neutral wiring, access 6 & 7 terminals.
3. When the control power voltage of F, X & M intelligent controllers are different requiring introducing different power supplies, it is not recommended to introduce back to the main circuit directly to provide high reliability to power supply.
4. Terminal #35 can access the power directly (automatic pre-energy storing), and be serially connected the normally open switch and power finally (energy storing of manual control).
5. Additional accessories are provided by the customer
6. Required by the customer, terminals #8-#9 can output normally closed contact (comm. provided products is in normally opened)
7. * If the intelligent controller applies DC work power, DC power modular is needed to be added while the terminals #1 and 2 could not access directly to the AC power, and the secondary circuit

- SBI shunt excitation button (provided by users for themselves) X switching-on electromagnet
- SB2 under-voltage button (provided by users for themselves) M energy-storage electric machine
- SB3 switching-on button (provided by users for themselves) XT connecting terminal

- DF auxiliary contact Q under-voltage release or under-voltage time delay release
- Fshunt release O normally open contact (3A/AC400V)
- Sensitive switch of SA electric machine ⊗ signal lamp (provided by users for themselves)..FU fuse

YCW3-1600 H Controller Wiring Diagram

Intelligent controller & Other Wirings

- #1 & #2 AC work power input (if DC is applicable, inputs through DC modular U1 & U2)
- #10 Remote communication & remote regulation of RS485 communication terminal A (+)
- #10 Remote control and measurement of RS485 communication terminal B (-)
- #12 Overload pre-alarm signal output
- #13 Discrete breaker output of communication remote control
- #14 Closing output of communication remote control
- #15 Energy storage output of communication remote control
- #16 Grounding or alarm signal output
- #17 Unload signal output 1
- #18 Load 2 or automatic re-close signal output
- #19 Signal output bus
- #20 Self-diagnostic alarm signal output
- #21 OCR fault trip signal output
- #22 A phase of power signal signal
- #23 B phase of power signal signal
- #24 J of C phase of power signal
- #25 & #26 External neutral or grounding current transformer input

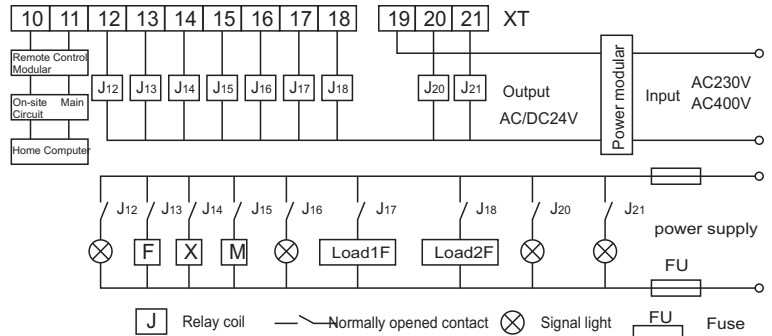

Wiring Diagram of Relay for Breaker Communication

- 1) Controller signal output through terminals 12-15. Make the additional relay J to output contact action signal
- 2) All protocol access modular and the power modular are provided by the manufacturer (voltage should be contained in order specification by the customer), power transformer can be inserted into standard guide together with the relay holder and mounted to the proper location in switch board by the customer.
- 3) Relay model: I-62P, AC/DC 24V, provided by customer
- 4) Home computer is provided by customer
- 5) Terminals 13-15 outputs can serve the remote switch ON/OFF and energy storage, the relay's normally opened contact can be linked with corresponding manual control button to realize both manual and remote controls.
- 6) The customer can select J12-15, J17 or J18 according to its own real conditions.

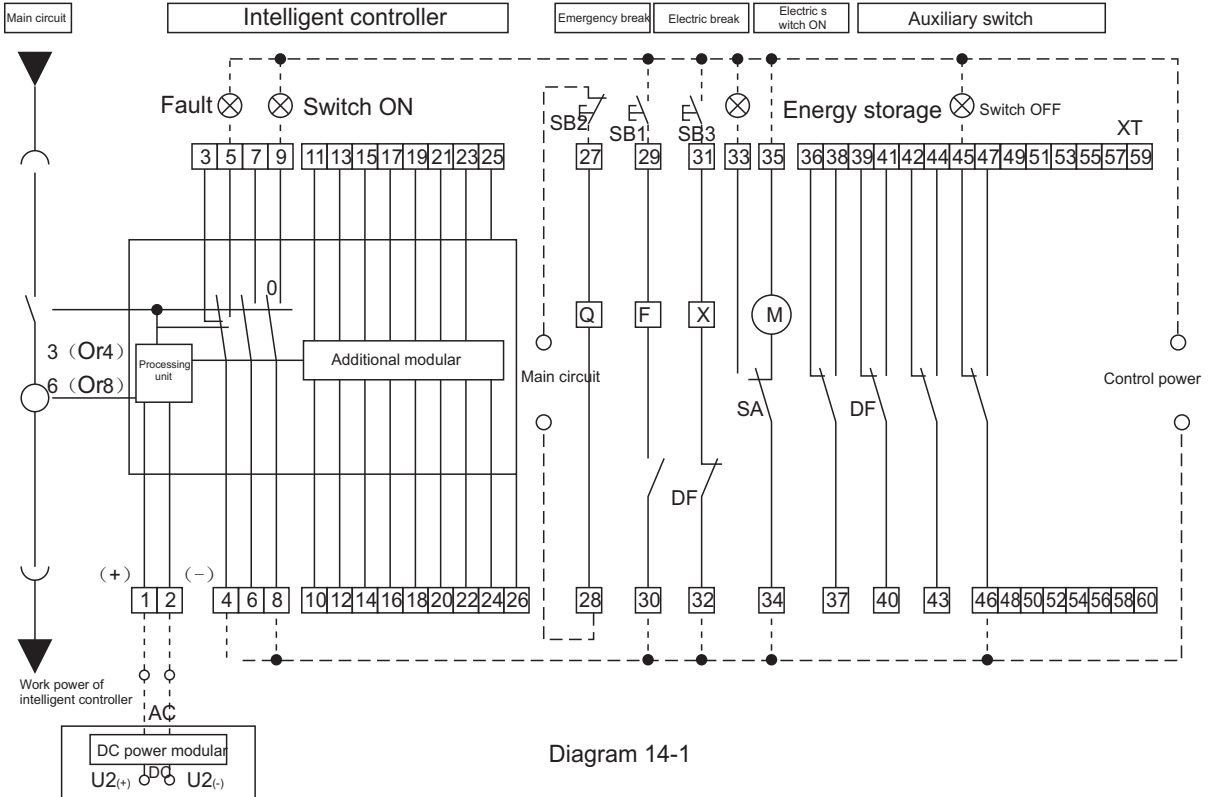

Diagram 14-1

- Notes:
1. All wiring in dashed area is completed by customer
 2. 6 & 7 terminals: if the current transformer is applicable for the external neutral wiring, access 6 & 7 terminals.
 3. When the control power voltage of F, X & M intelligent controllers are different requiring introducing different power supplies, it is not recommended to introduce back to the main circuit directly to provide high reliability to power supply.
 4. Terminal #35 can access the power directly (automatic pre-energy storing), and be serially connected the normally open switch and power finally (energy storing of manual control).
 5. Additional accessories are provided by the customer
 6. Required by the customer, terminals #8-#9 can output normally closed contact (comm. provided products is in normally opened)
 7. * If the intelligent controller applies DC work power, DC power modular is needed to be added while the terminals #1 and 2 could not access directly to the AC power, and the secondary circuit

- | | | | |
|--|-----------------------------------|---|---|
| SBI shunt excitation button (provided by users for themselves) | X switching-on electromagnet | DF auxiliary contact | Q under-voltage release or under-voltage time delay release |
| SB2 under-voltage button (provided by users for themselves) | M energy-storage electric machine | F shunt release | ○ normally open contact (3A/Ac400V) |
| SB3 switching-on button (provided by users for themselves) | XT connecting terminal | Sensitive switch of SA electric machine | ⊗ signal lamp (provided by users for themselves).FU fuse |

YCW3-2000-6300 H Controller Wiring Diagram(Conventional type)

Intelligent controller & Other Wirings

- #1 & #2 AC work power input (if DC is applicable, inputs through DC modular U1 & U2)
- #10 Remote communication & remote regulation of RS485 communication terminal A (+)
- #10 Remote control and measurement of RS485 communication terminal B (-)
- #12 Overload pre-alarm signal output
- #13 Discrete breaker output of communication remote control
- #14 Closing output of communication remote control
- #15 Energy storage output of communication remote control
- #16 Grounding or alarm signal output
- #17 Unload signal output 1
- #18 Load 2 or automatic re-close signal output
- #19 Signal output bus
- #20 Self-diagnostic alarm signal output
- #21 OCR fault trip signal output
- #22 A phase of power signal signal } is directly input
- #23 B phase of power signal signal } through main circuit
- #24 J of C phase of power signal } through main circuit
- #25 & #26 External neutral or grounding current transformer input

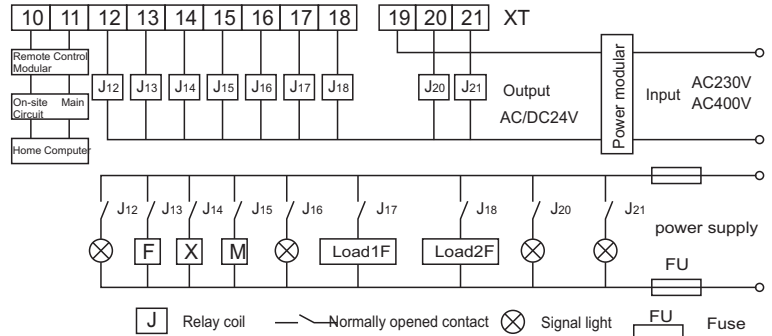

Wiring Diagram of Relay for Breaker communication

- 1) Controller signal output through terminals 12-15. Make the additional relay J to output contact action signal
- 2) All protocol access modular and the power modular are provided by the manufacturer (voltage should be contained in order specification by the customer), power transformer can be inserted into standard guide together with the relay holder and mounted to the proper location in switch board by the customer.
- 3) Relay model: I-62P, AC/DC 24V, provided by customer
- 4) Home computer is provided by customer
- 5) Terminals 13-15 outputs can serve the remote switch ON/OFF and energy storage, the relay's normally opened contact can be linked with corresponding manual control button to realize both manual and remote controls.
- 6) The customer can select J12-15, J17 or J18 according to its own real conditions.

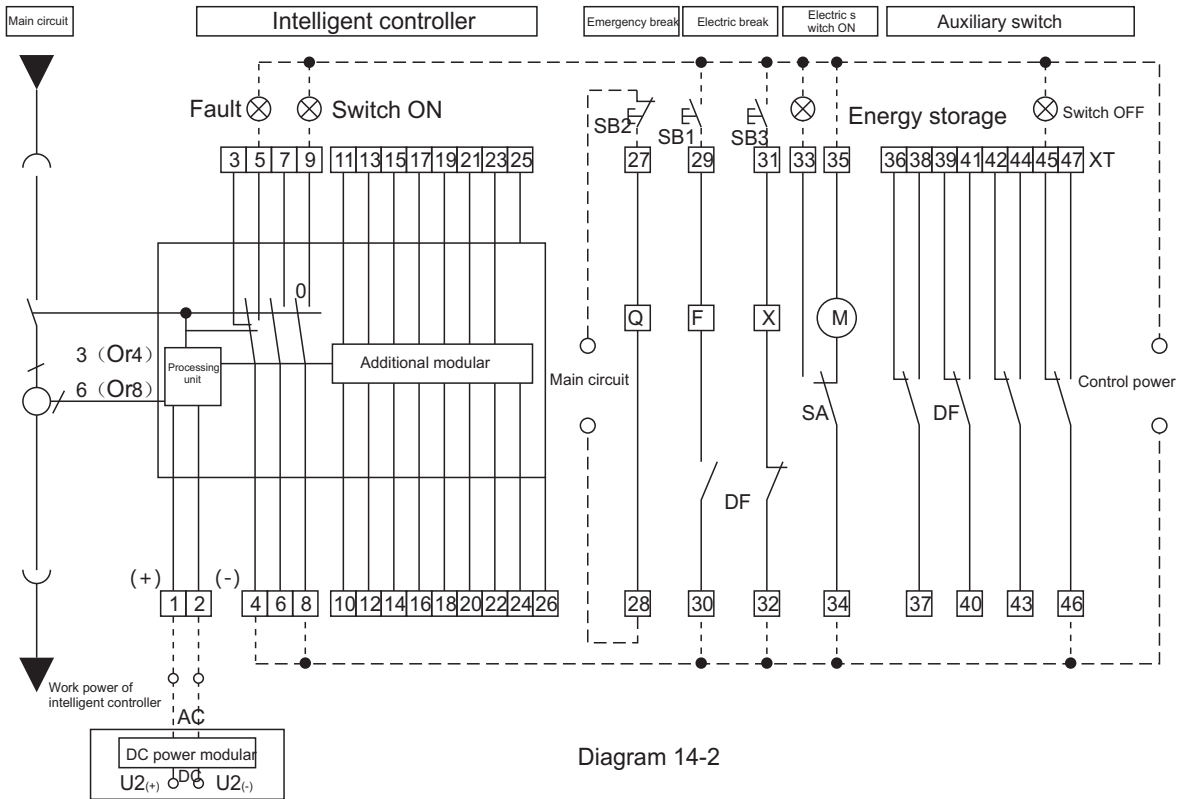

Diagram 14-2

- Notes: 1. All wiring in dashed area is completed by customer
2. 6 & 7 terminals: if the current transformer is applicable for the external neutral wiring, access 6 & 7 terminals.
3. When the control power voltage of F, X & M intelligent controllers are different requiring introducing different power supplies, it is not recommended to introduce back to the main circuit directly to provide high reliability to power supply.
4. Terminal #35 can access the power directly (automatic pre-energy storing), and be serially connected the normally open switch and power finally (energy storing of manual control).
5. Additional accessories are provided by the customer
6. Required by the customer, terminals #8-#9 can output normally closed contact (comm. provided products is in normally opened)
7. * If the intelligent controller applies DC work power, DC power modular is needed to be added while the terminals #1 and 2 could not access directly to the AC power, and the secondary circuit

- | | | | |
|--|-----------------------------------|---|---|
| SBI shunt excitation button (provided by users for themselves) | X switching-on electromagnet | DF auxiliary contact | Q under-voltage release or under-voltage time delay release |
| SB2 under-voltage button (provided by users for themselves) | M energy-storage electric machine | F shunt release | O normally open contact (3A/AC400V) |
| SB3 switching-on button (provided by users for themselves) | XT connecting terminal | Sensitive switch of SA electric machine | ⊗ signal lamp (provided by users for themselves).FU fuse |

YCW3-2000~6300 Secondary Circuit Wiring for Breaker of H Intelligent Controller (Auxiliary switch contact with 4-NO & 4-NC)

Intelligent controller & Other Wirings

- #1 & #2 AC work power input (if DC is applicable, inputs through DC modular U1 & U2)
- #10 RS485 communication terminal A (+) } remote communication & remote regulation
- #10 RS485 communication terminal B (-) } remote control, remote measurement etc.
- #12 Overload pre-alarm signal output
- #13 Discrete break output of communication remote control
- #14 Closing output of communication remote control
- #15 Energy storage output of communication remote control
- #16 Alarm remark output of intelligent release (or electric leakage alarm signal)
- #17 unload signal output 1
- #18 Unload 2 or automatic re-close signal output
- #19 Signal output bus
- #20 Self-diagnostic alarm signal output
- #21 OCR fault trip signal output
- #22 A phase of power signal
- #23 B phase of power signal } is directly input through main circuit
- #24 C phase of power signal }
- #25 & #26 External neutral or grounding current transformer input

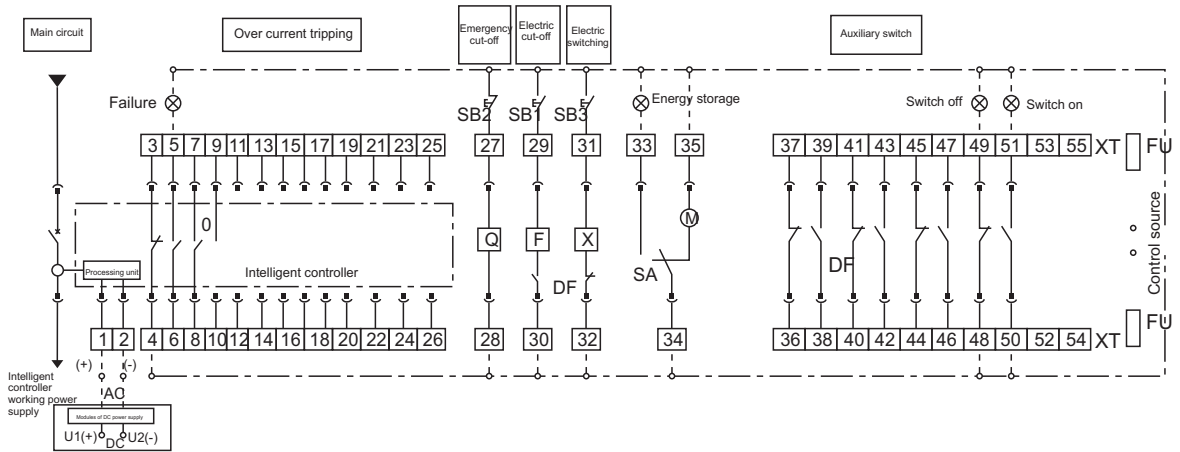

Diagram 14-3

Notes:

1. All wiring in dashed area is completed by customer
2. 6 & 7 terminals: if the current transformer is applicable for the external neutral wiring, access 6 & 7 terminals.
3. When the control power voltage of F, X & M intelligent controllers are different requiring introducing different power supplies, it is not recommended to introduce back to the main circuit directly to provide high reliability to power supply.
4. Terminal #35 can access the power directly (automatic pre-energy storing), and be serially connected the normally open switch and power finally (energy storing of manual control).
5. Additional accessories are provided by the customer
6. Required by the customer, terminals #8-#9 can output normally closed contact (comm. provided products is in normally opened)
7. * If the intelligent controller applies DC work power, DC power modular is needed to be added while the terminals #1 and 2 could not access directly to the AC power, and the secondary circuit

SBI shunt excitation button (provided by users for themselves)
 SB2 under-voltage button (provided by users for themselves)
 SB3 switching-on button (provided by users for themselves)

X switching-on electromagnet
 M energy-storage electric machine
 XT connecting terminal

DF auxiliary contact
 F shunt release
 Sensitive switch of SA electric machine

Q under-voltage release or under-voltage time delay release
 O normally open contact (3A/Ac400V)
 ⊗ signal lamp (provided by users for themselves)..FU fuse

YCW3-2000~6300 Secondary Circuit Wiring for Breaker of H Intelligent Controller (Auxiliary switch contact with 6-NO & 2-NC)

Secondary Circuit Wiring for Breaker of H Intelligent Controller (Auxiliary switch contact with 6-NO & 2-NC) Intelligent controller & Other Wirings

- #1 & #2 AC work power input (if DC is applicable, inputs through DC modular U1 & U2)
- #10 RS485 communication terminal A (+) } remote communication & remote regulation
- #11 RS485 communication terminal B (-) } remote control, remote measurement etc.
- #12 Overload pre-alarm signal output
- #13 Discrete break output of communication remote control
- #14 Closing output of communication remote control
- #15 Energy storage output of communication remote control
- #16 Alarm remark output of intelligent release (or electric leakage alarm signal)
- #17 Unload signal output 1
- #18 Unload 2 or automatic re-close signal output
- #19 Signal output bus
- #20 Self-diagnostic alarm signal output
- #21 OCR fault trip signal output
- #22 A phase of power signal
- #23 B phase of power signal } is directly input through main circuit
- #24 C phase of power signal }
- #25 & #26 External neutral or grounding current transformer input

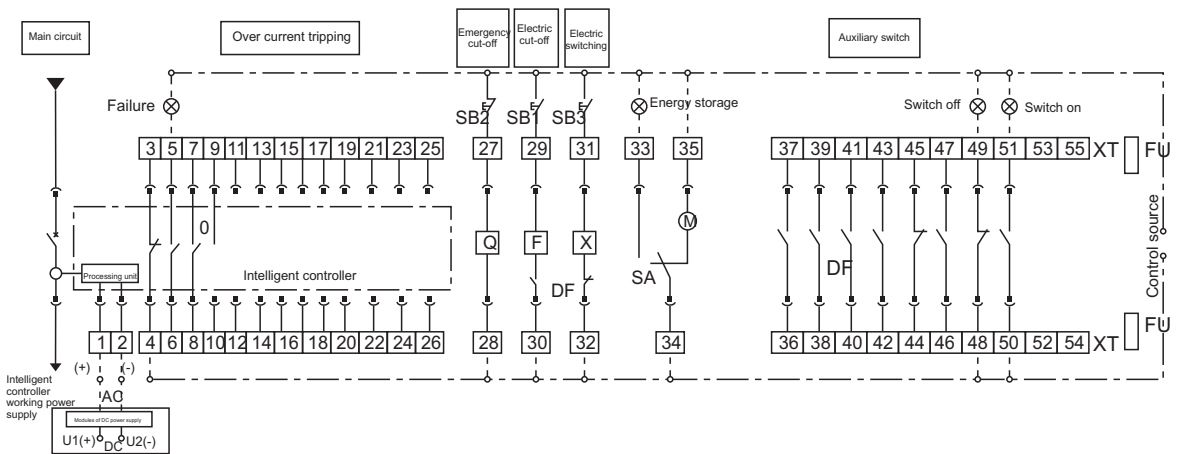

Diagram 14-4

Notes:

1. All wiring in dashed area is completed by customer
2. 6 & 7 terminals: if the current transformer is applicable for the external neutral wiring, access 6 & 7 terminals.
3. When the control power voltage of F, X & M intelligent controllers are different requiring introducing different power supplies, it is not recommended to introduce back to the main circuit directly to provide high reliability to power supply.
4. Terminal #35 can access the power directly (automatic pre-energy storing), and be serially connected the normally open switch and power finally (energy storing of manual control).
5. Additional accessories are provided by the customer
6. Required by the customer, terminals #8-#9 can output normally closed contact (comm. provided products is in normally opened)
7. * If the intelligent controller applies DC work power, DC power modular is needed to be added while the terminals #1 and 2 could not access directly to the AC power, and the secondary circuit

SB1 shunt excitation button (provided by users for themselves)
 SB2 under-voltage button (provided by users for themselves)
 SB3 switching-on button (provided by users for themselves)

X switching-on electromagnet
 M energy-storage electric machine
 XT connecting terminal

DF auxiliary contact
 F shunt release
 Sensitive switch of SA electric machine

Q under-voltage release or under-voltage time delay release
 O normally open contact (3A/AC400V)
 ⊗ signal lamp (provided by users for themselves).FU fuse

YCW3-2000~6300 Secondary Circuit Wiring for Breaker of H Intelligent Controller (Auxiliary switch contact with 3-NO & 3-NC)

Other connecting wires of intelligent controller

- #1, #2 AC working power supply input (input from DC modules of U1 and U2 in the case of the direct current)
 - #10 Remote communication and regulation of terminal 1 of RS485 communication A (+)
 - #11 Remote control and measurement of terminal J of RS485 communication B
 - #12 Output of overload pre-alarming signal
 - #13 Output of communication remote-control shunt tripping
 - #14 Output of communication remote-control switching on
 - #15 Output of communication remote-control energy storage
 - #16 Output of intelligent release alarming signal output (or electric leakage alarming signal)
 - #17 Output of disposable load 1 signal
 - #18 Output of disposable load 2 or automatic re-closing signal
 - #19 Signal output common
 - #20 Output of self-diagnostic alarming signal
 - #210 Output of CR fault tripping signal
 - #22 A phase of power supply signal
 - #23 B phase of power supply signal
 - #24 C phase of power supply signal
 - #25, 26 Input of neutrality-pole or ground current transformer
- } is directly inputted from the major loop

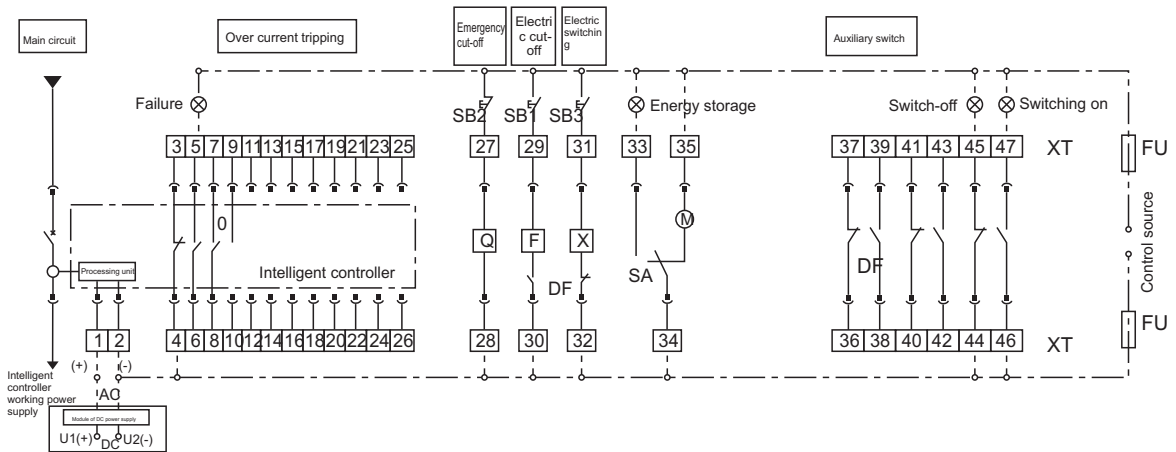

Figure 14-5

Notes:

1. All wiring in dashed area is completed by customer
2. 6 & 7 terminals: if the current transformer is applicable for the external neutral wiring, access 6 & 7 terminals.
3. When the control power voltage of F, X & M intelligent controllers are different requiring introducing different power supplies, it is not recommended to introduce back to the main circuit directly to provide high reliability to power supply.
4. Terminal #35 can access the power directly (automatic pre-energy storing), and be serially connected the normally open switch and power finally (energy storing of manual control).
5. Additional accessories are provided by the customer
6. Required by the customer, terminals #8-#9 can output normally closed contact (comm. provided products is in normally opened)
7. * If the intelligent controller applies DC work power, DC power modular is needed to be added while the terminals #1 and 2 could not access directly to the AC power, and the secondary circuit

- | | | |
|--|-----------------------------------|---|
| SBI shunt excitation button (provided by users for themselves) | X switching-on electromagnet | DF auxiliary contact |
| SB2 under-voltage button (provided by users for themselves) | M energy-storage electric machine | F shunt release |
| SB3 switching-on button (provided by users for themselves) | XT terminal | Sensitive switch of SA electric machine |

- Q under-voltage release or under-voltage release of time delay
- O normally open contact (3A/Ac400V)
- ⊗ signal lamp (provided by users for themselves)..FU fuse

6 Overall and Mounting Dimensions

6.1 YCW3-1600A Fixed Circuit-Breaker Installation and Overall Dimensions are shown in Figure 15.

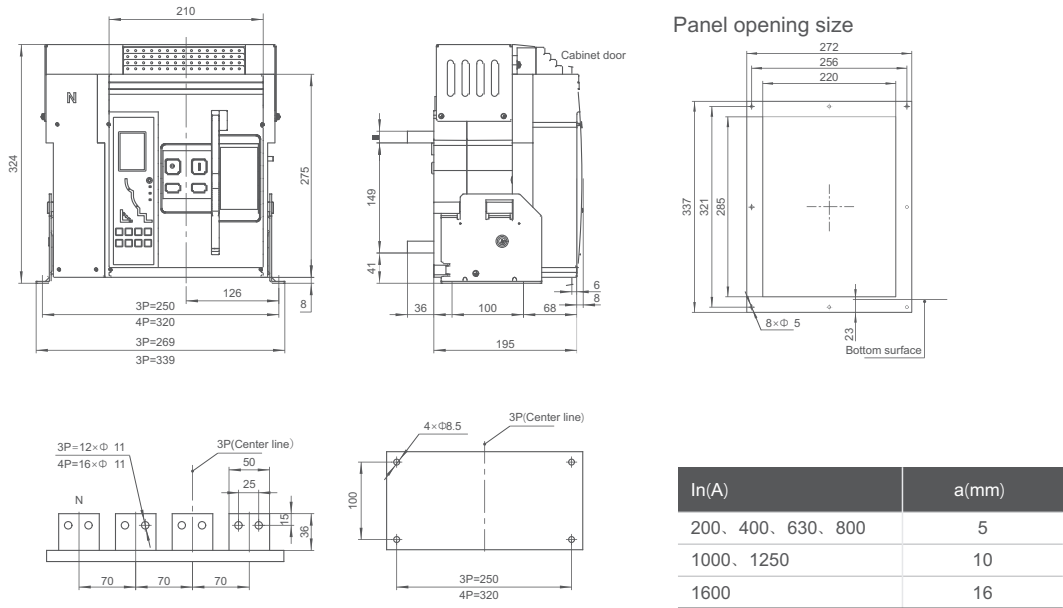

6.2 YCW3-2000A Fixed Circuit-Breaker Installation and Overall Dimensions are shown in Figure 16.

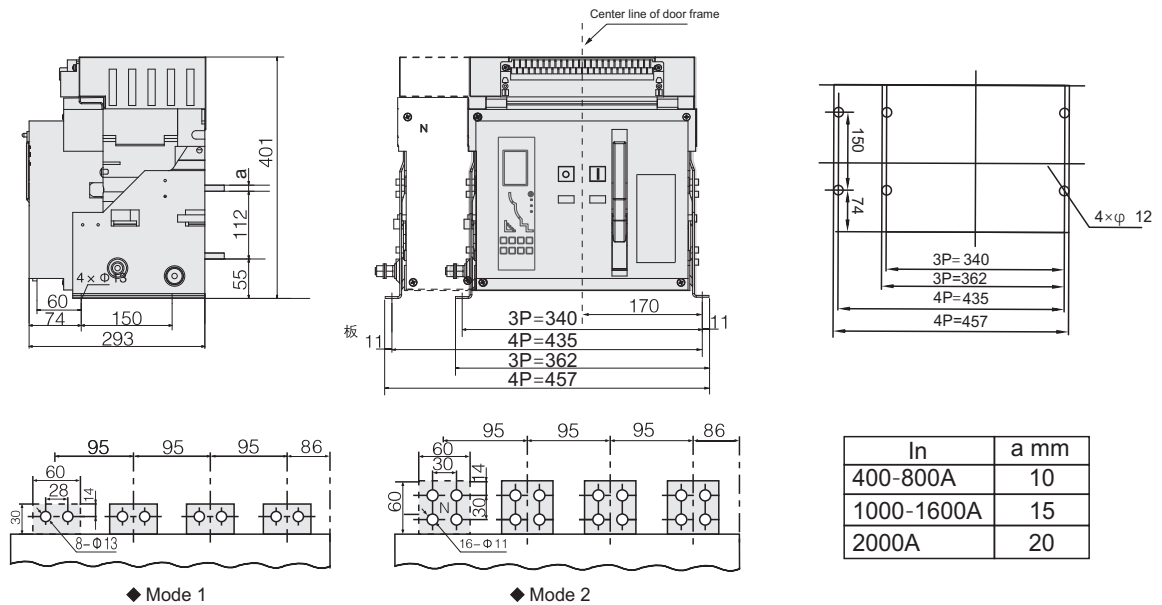

Note: Regular default Mode 1; When using Mode 2, please remark the extended busbar after the model to place an order

6.3 YCW3-2500A Fixed Circuit-Breaker Installation and Overall Dimensions are shown in Figure 17 .

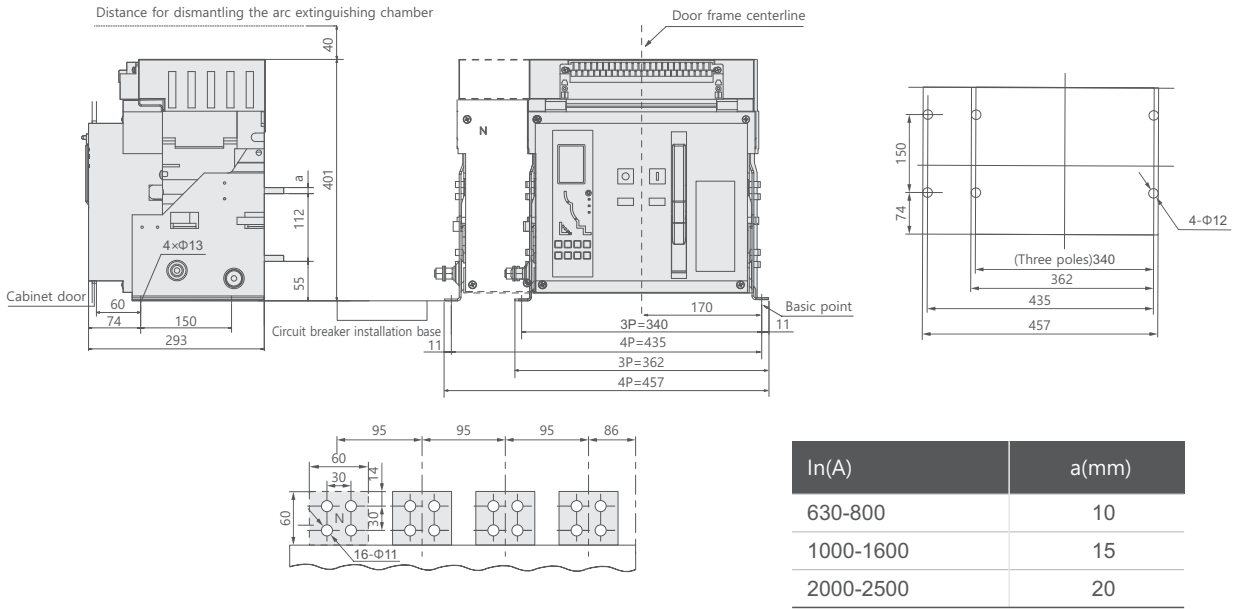

6.4 YCW3-3200A Fixed Circuit-Breaker Installation and Overall Dimensions are shown in Figure 18.

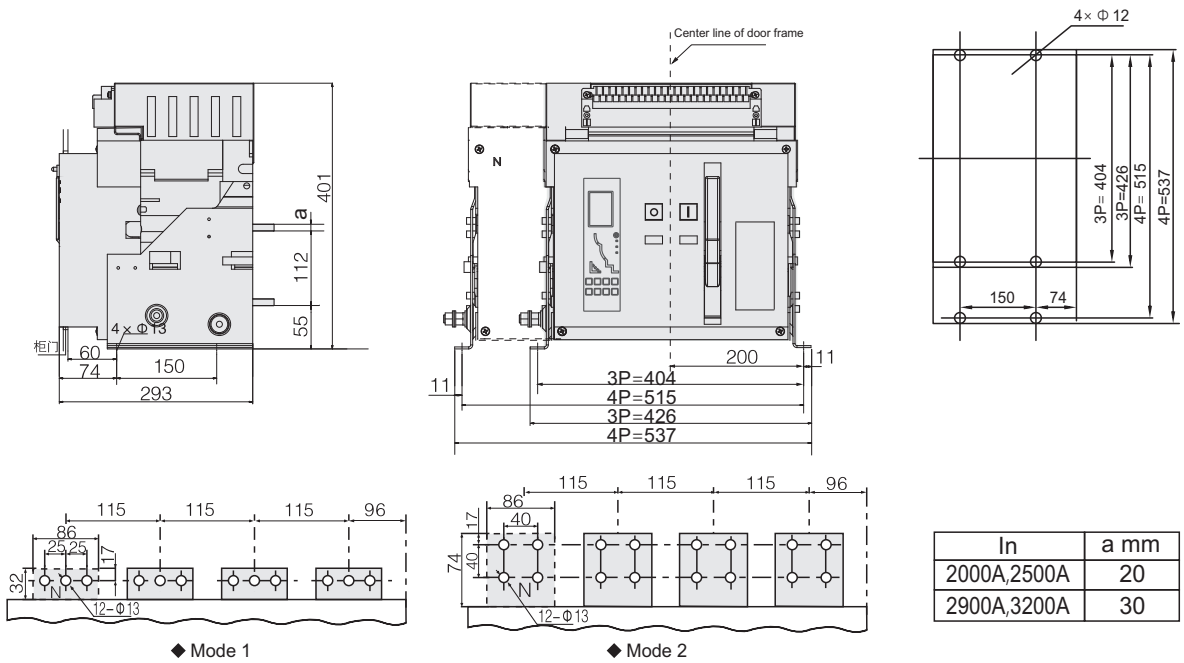

Note: Regular default Mode 1;When using Mode 2, please remark the extended busbar after the model to place an order

6.5 YCW3-4000A Fixed Circuit-Breaker Installation and Overall Dimensions are shown in Figure 19.

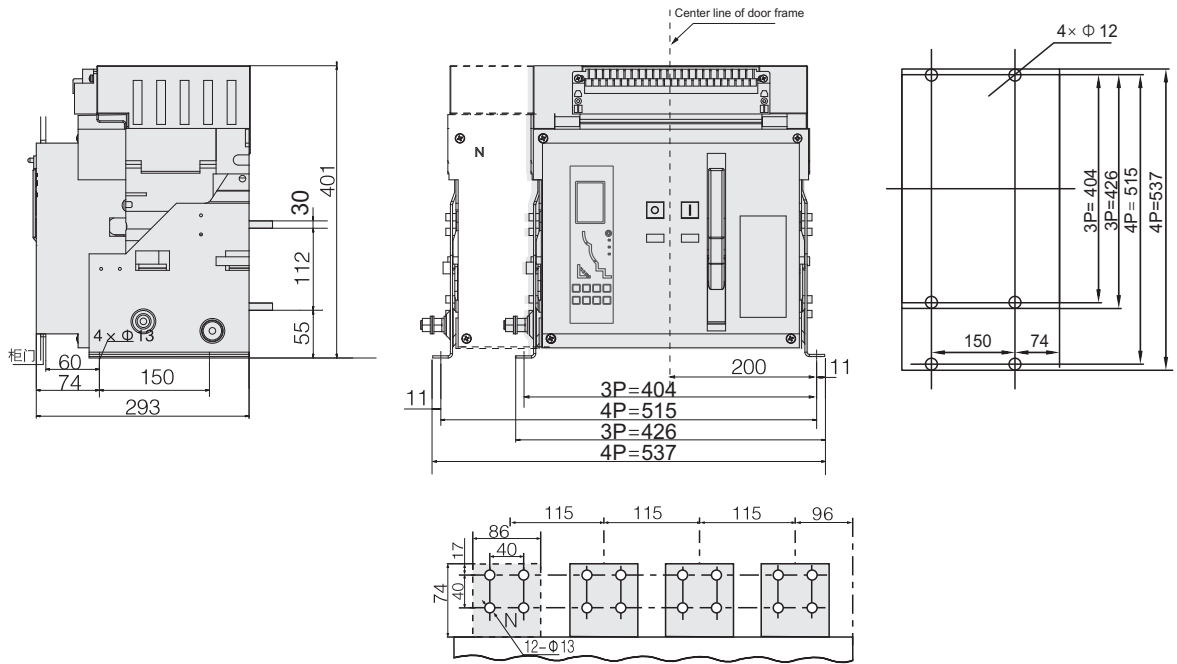

6.6 YCW3-4000A Fixed Circuit-Breaker Installation and Overall Dimensions are shown in Figure 20 .
(YCW1-4000/3 Fixed type Alternative)

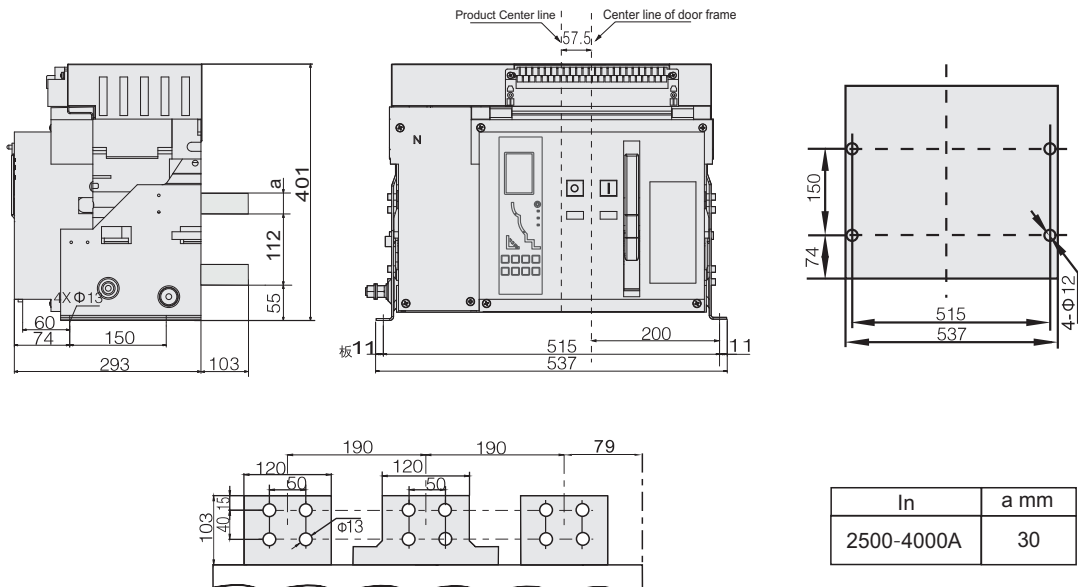

6.7 The installation of YCW3-6300/3P fixed circuit breaker and overall dimension are shown in Figure 21 .

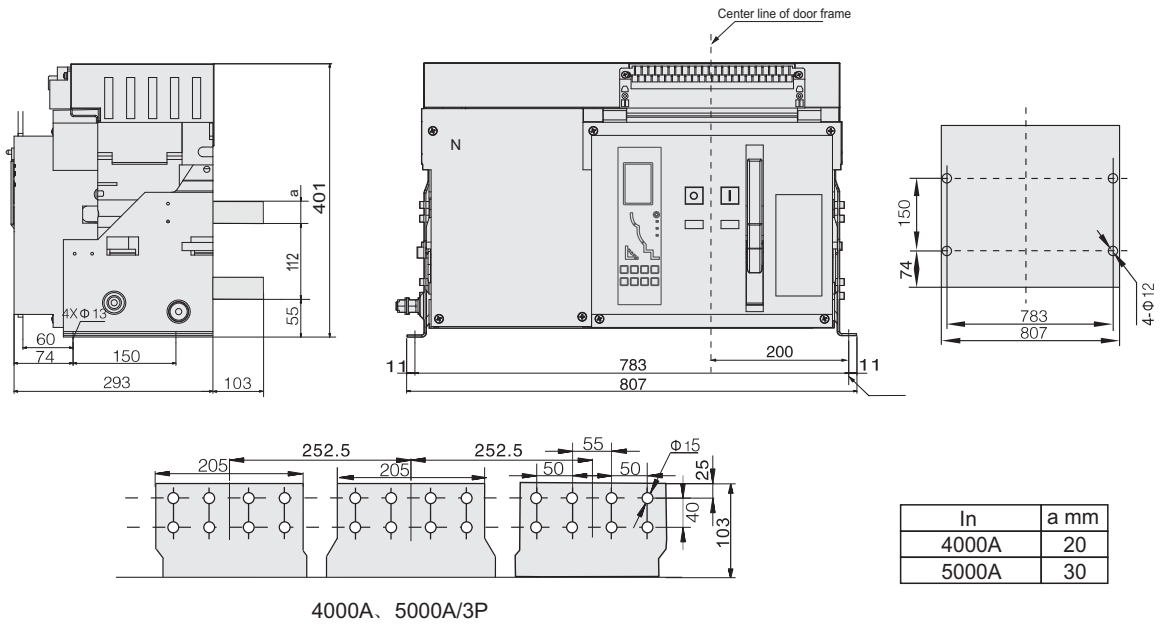

6.8 The installation of YCW3-6300 A fixed circuit breaker and overall dimension are shown in Figure 22.

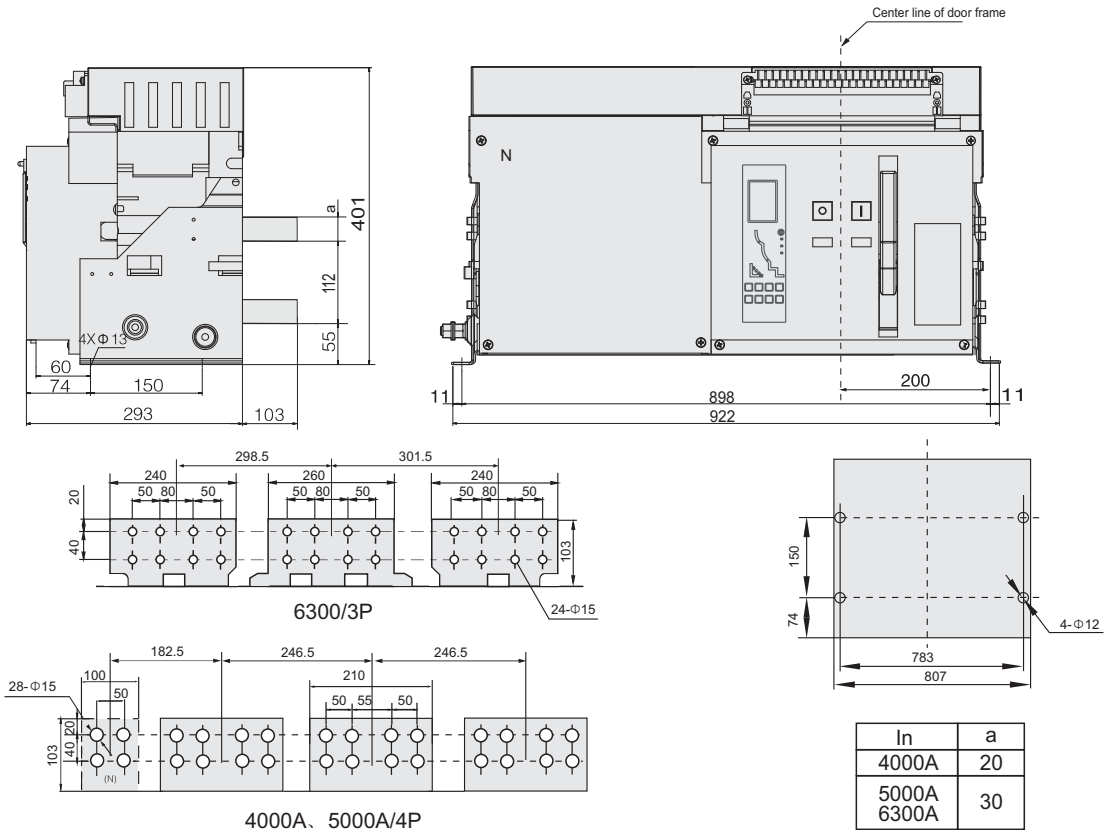

6.9 The installation of YCW3-1600A drawer circuit breaker and overall dimension are shown in Figure 23.

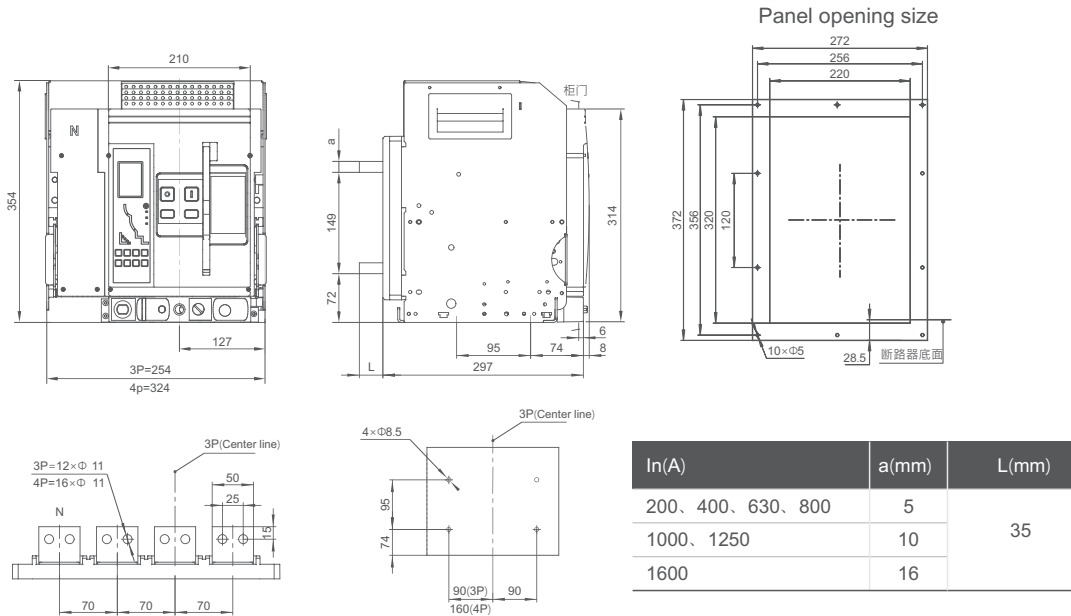

6.10 Outline & Installation size of YCW3-2000A Drawer Breaker refer to Diagram 24.

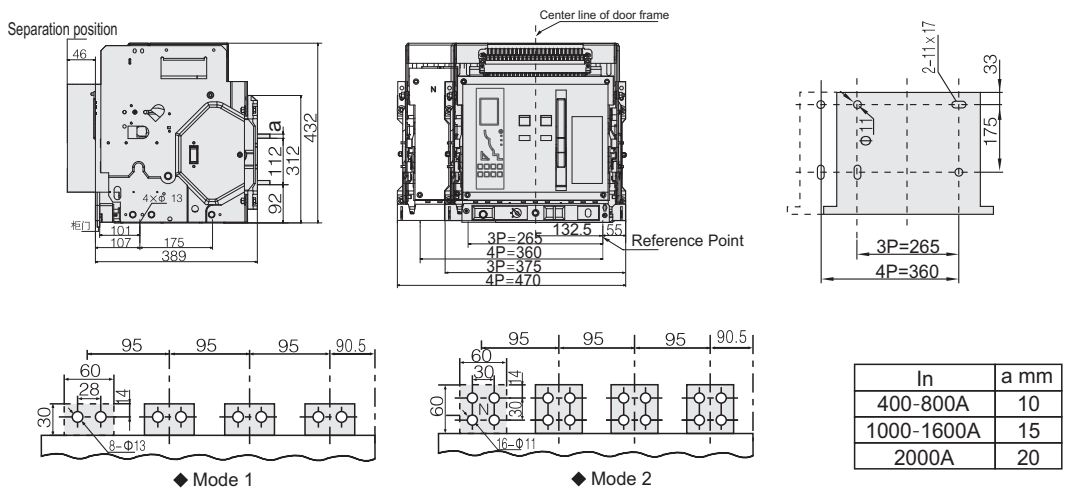

Note: Regular default Mode 1; When using Mode 2, please remark the extended busbar after the model to place an order

6.9 The installation of YCW3-2500A drawer circuit breaker and overall dimension are shown in Figure 25.

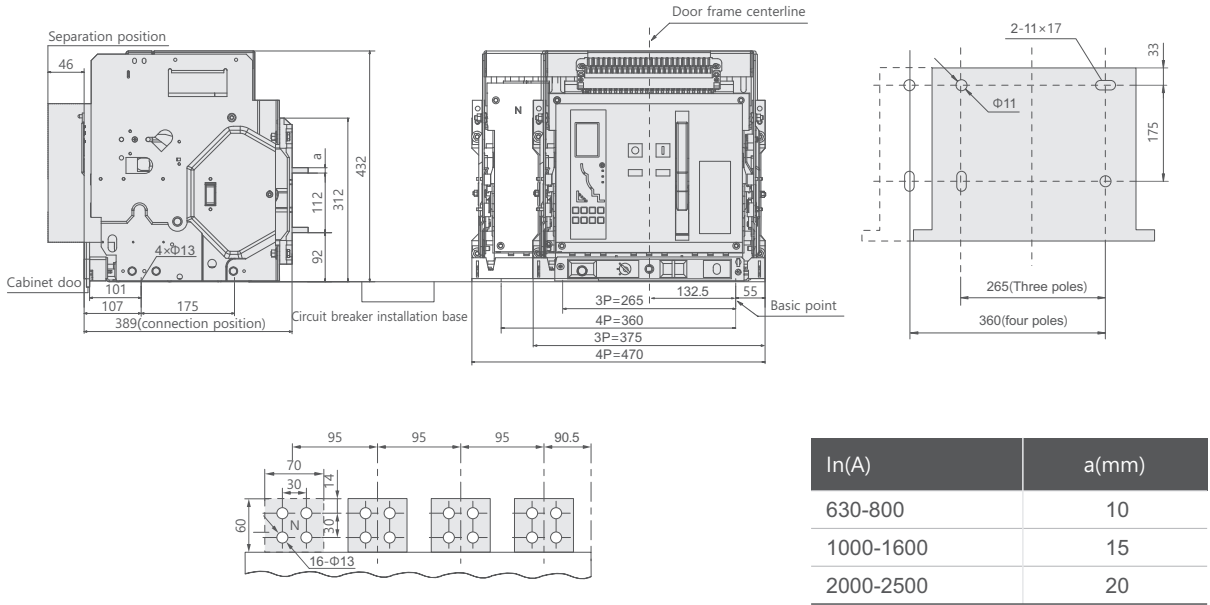

6.12 The shape of YCW3-3200A drawer circuit breaker and installation size are shown in the Figure 26.

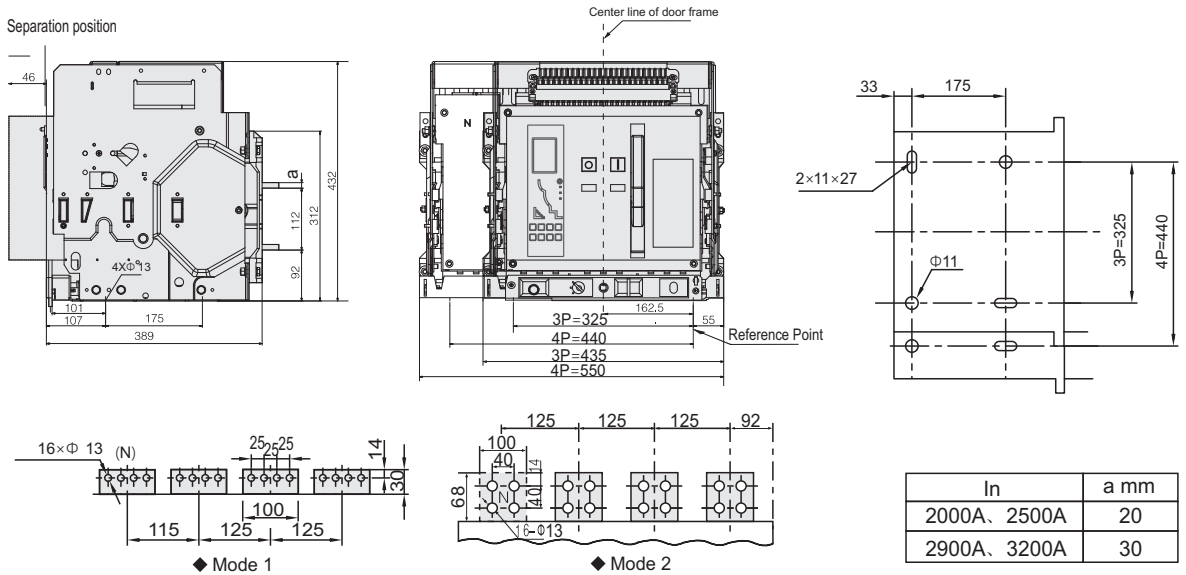

Note: Regular default Mode 1; When using Mode 2, please remark the extended busbar after the model to place an order

6.13 Outline & Installation size of YCW3-4000A Drawer Breaker refer to Diagram 27.

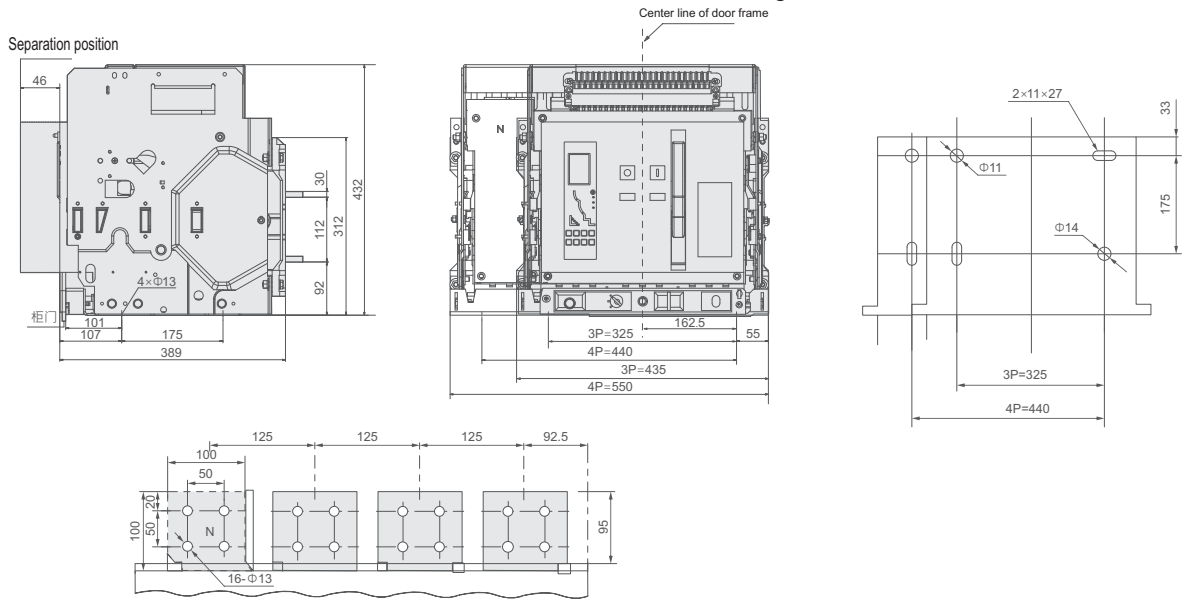

6.14 The shape of YCW3-4000A drawer circuit breaker and installation size are shown in the Figure 28. (YCW1-4000/3 Drawer Alternative)

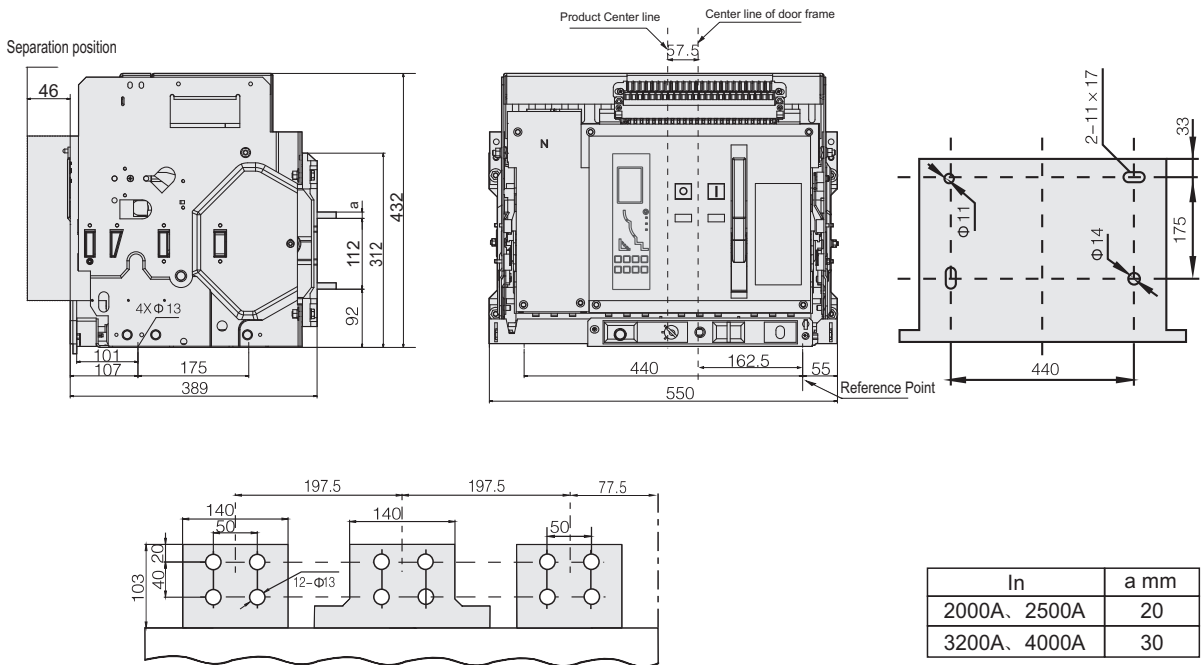

In	a mm
2000A、2500A	20
3200A、4000A	30

6.15 Figure 29 Shape of YCW3—6300 /3P drawer circuit breaker (quadropole) and installation size.

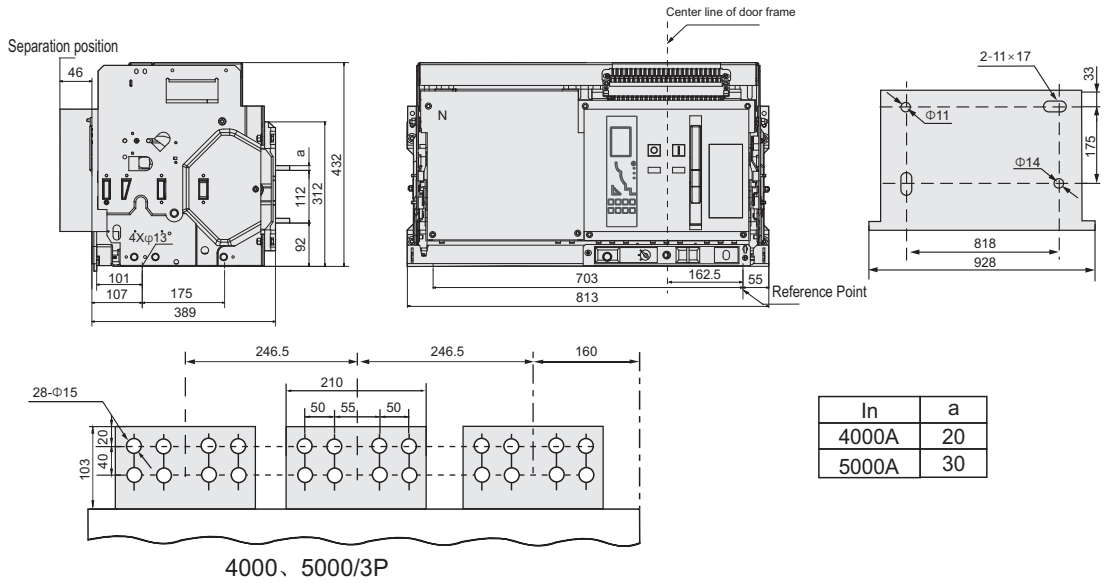

6.16 Installation of YCW3-6300A drawer circuit breaker and overall dimension are shown in the Figure 30.

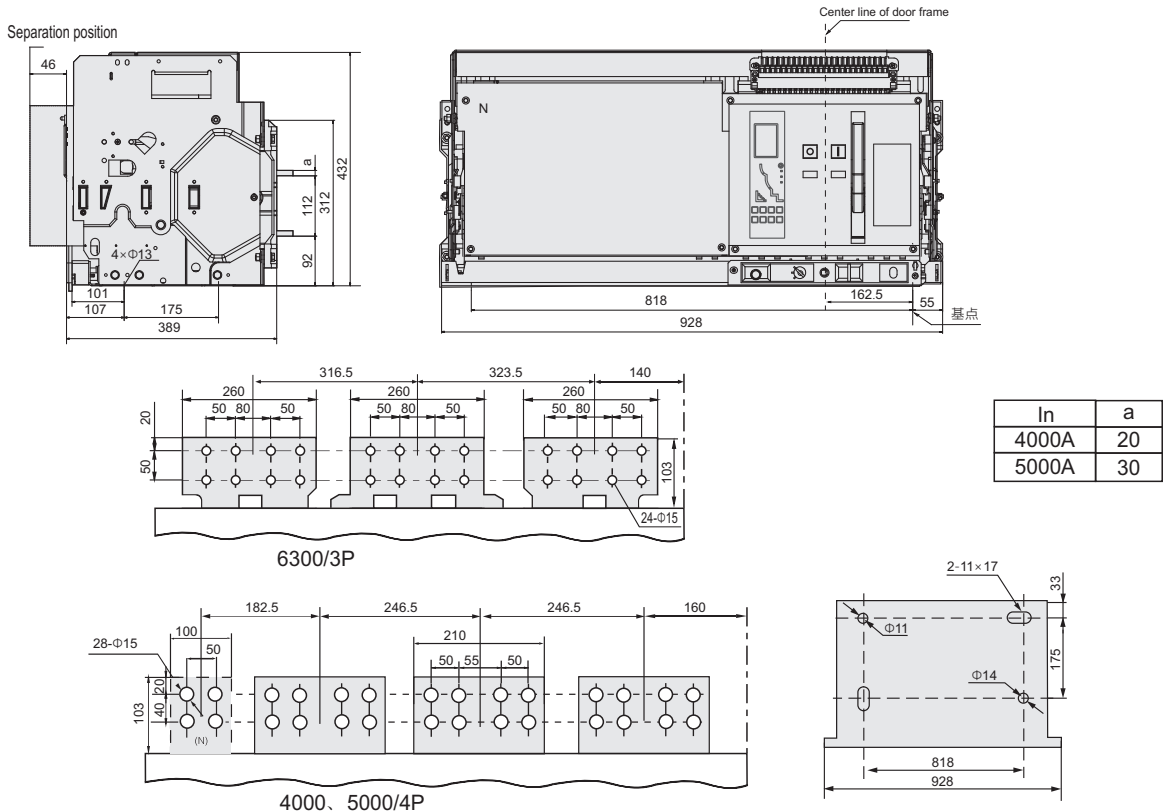

6.17 Installation size for panel drilling is shown in the Figure 29 and Table 10

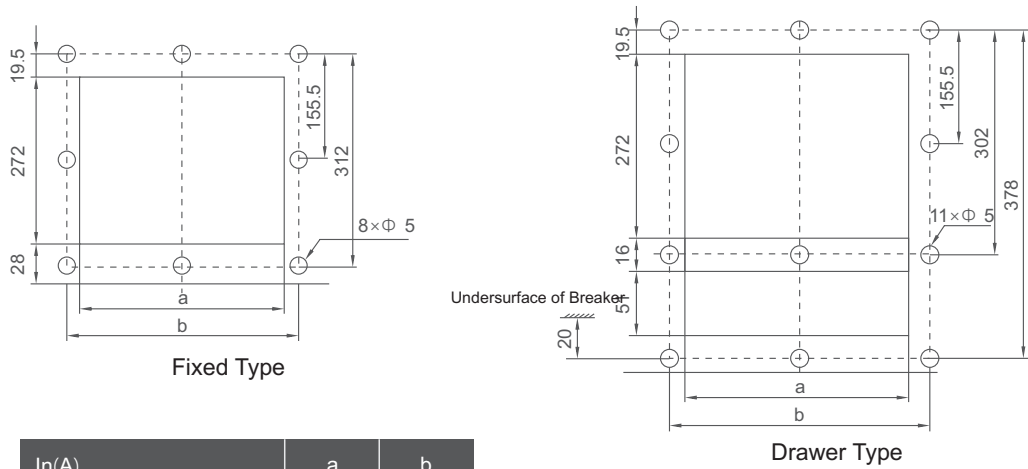

In(A)	a	b
YCW3-2000	306	346
YCW3-3200-6300	366	406

Installation size for panel drilling

6.18 Interlocking mechanism of the breaker is shown in Figure 30a and 30b

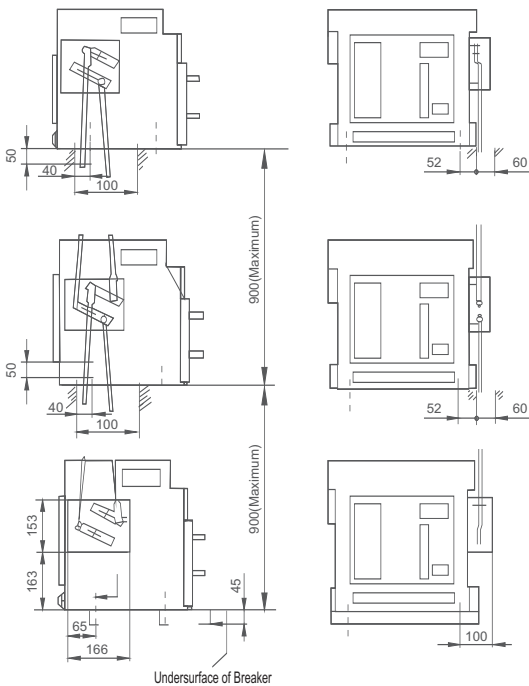

Note:
Two horizontal circuit breakers interlocked by the steel cable (fixed type or drawer type)
On the Figure 30b is the interlocking mechanism of the horizontal circuit breaker.

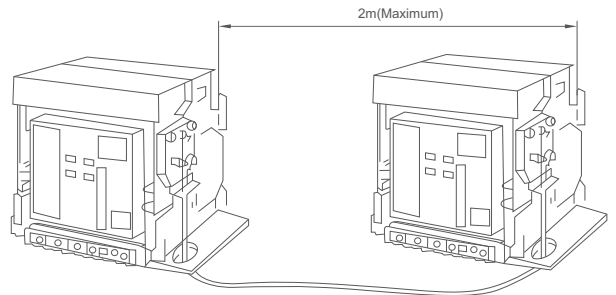

30b

Figure 30a Interlocking Mechanism of the Vertically-installed Breaker

7. Installation, use and maintenance

7.1 Installation

Examine the specification of circuit breaker complying with the requirements or not prior to installation. Examine insulation resistance by 500V megohmmeter. It should be less than 10M under the 205°C surrounding medium and 50%~70% relative humidity, otherwise it should be dried. Use it until the insulation resistance reaching the requirements.

When installation, its base should be in horizontal position and fixed by M10 bolt. Do reliable protection grounding on the circuit breaker and mark notably on grounding point. The fixed circuit breaker should strictly comply with safety area.

After finishing installation of circuit breaker, do wiring as per relevant wire connection drawing. Conduct following operation and testing prior to main circuit power on (the indication of drawer base of draw-out circuit breaker is in testing position):

- a. Examine under-voltage, if shunt release tripping, closed electromagnet and voltage of electronic operation in line (under-voltage release should pull in and the circuit breaker can operates.)
- b. Pull the handle of cover up and down 7 times. The plate displays "energy storage" and there is "clatter" sound; it means energy storage finish. Press "1" button or closed electromagnet power on. The circuit breaker can be closed reliably (the release reset is shown in No. 1 Table 24) and pull the handle for energy storage again.
- c. From electromotor power on to "energy storage" on the plate, the clatter often follows. When energy storage finish, the electromotor will automatically cut off. Pressing "I" button or closing electromagnet power on, the circuit breaker can be closed reliably.
- d. After closing the circuit breaker, all under-voltage, shunt release or "0" button on the cover, intelligent release experiments can enable the circuit breaker breaking.

7.2 Intelligent release use (shown in Table 24)

7.2.1 Release setting

Press "amp-clearing" to set long-time delay for the release. Press "et" until the long-time delay indication lamp is on and displaying long-time delay current setting value of Ex-factory. It's generally In with range of (0.4~1.0)In. Press "+" and "-" according to requirements as per not more than 2% intervals to increase or reduce every time, until the required current is coming. Press "storage" while the storage indication lamp lights is on at first and then out, which means long-time delay current setting value has been stored.

After long-time delay time setting and long-time delay current setting value, press "set" again, long-time delay indication lamp is on and displaying long-time delay current setting value. Press "+" at intervals of double time every time. Press "-" again for too long the time. While pressing one time, it can reduce half time until the required time is coming. While press "storage" again, the storage indication lamp is on, then out, which means long-time delay setting storage finish. For load monitoring, short-time delay, instantaneous and grounding protection, it only alarms and has no tripping. While the instantaneous setting is "off", it means protection cancelled. During the release setting, available position means failure situation. During setting, once is failure signal, the release automatically locks into failure treatment situation.

It shouldn't set across protection parameter for the release. For I_{C1} value of Reclosing less than I_{C2} , press "lamp-clearing" again or cut-off and reset to enable the release under operating situation after setting all parameters of release.

7.2.2 Release testing

After setting release parameters and before operating circuit breaker, it's necessary to examine protection function of release. Select tripping or no tripping of release testing. While pressing "tripping" for the testing, the circuit breaker breaks, vice versa.

For convenient testing, treat action position no matter grounding setting on the action position or alarm position and the overload current is more than grounding current. For overload testing, press "et" to long-time delay situation. Check overload setting value I_{r1} , then other current situation. Press "+" and "-" to regulate it.

When the current is not less than $1.3I_{r1}$, press testing button and enter into overload testing situation. The time delay action of release is as per inverse rules and indicating failure and testing situation. Other characteristic testing is the same. After testing finish, press "amp-clearing" and enter into normal operation, meanwhile, press "resetting" to close the circuit breaker.

7.2.3 Other rules for release use

While setting and examining the situation, the release automatically clears and works normally in min without pressing button. Once failure occurs, it will lock button function and enter failure treatment situation.

□ Setting examination

After "lamp-clearing " of release, under no failure condition, continuously press "set" to circulate and indicate the current value and time of each situation. After examination, press"lamp-clearing ".If not pressing it in 1 min, it will automatically operate normally.

□ Electric network current and voltage examination

After "lamp-clearing " of release, under no failure condition, continuously press (select) button to circulate and indicate the current value and time of each situation, normally maximum phase current. Continuously press (select) button to circulate and indicate the phase voltage, normally maximum phase current

After "lamp-clearing " , press"failure examination " button, it displays previous failure and failure current. After testing or failure tripping, pressing (select) button can circulate and indicate the current value and the time of testing or failure and the testing situation will not be memorized.

□ Reset: with the auxiliary power, before closing the circuit breaker, it's necessary to press"lamp-clearing " and enable the release operating normally, then pres\$reset"to close the circuit breaker.

7.3 Other rules for release use

Light indication

- ① LCD display
- ② Long delay protection
- ③ Short delay protection
- ④ Ground fault protection
- ⑤ warn/Alarm
- ⑥ Healthy
- ⑦ Bus
- ⑧ Short delay protection
- ⑨ Instantaneous protection

Button Function description

- ⑩ Measuring function key
- ⑪ Set Key
- ⑫ +/- Turn the page
- ⑬ -/ Turn the page
- ⑭ Protect function key
- ⑮ Historical record
- ⑯ Select confirm key
- ⑰ Exit Button
- ⑱ Reset key

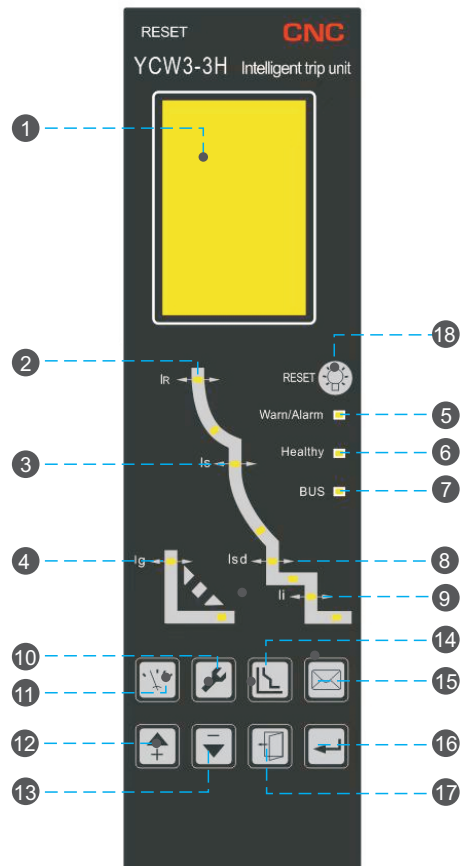

8. Failure analysis and recovery

Common failure and recovery method are shown in Table 11

Table 11

Common failure	Reason analysis	Recovery method
Circuit breaker trip (failure indication lamp is on)	Ground-load tripping (long-time delay indication lamp is on)	Examine tripping current value and operating time of controller, find out the failure and recover. Press to close the circuit breaker.
	short circuit tripping (short-time delay or instantaneous indication lamp is on)	Examine tripping current value and operating time of controller, find out the failure and recover. Press to close the circuit breaker.
	Grounding failure tripping and grounding failure indication lamp is on	Examine tripping current value and operating time of controller, find out the failure and recover. Press to close the circuit breaker.
	Under-voltage release tripping	1)Examine if the voltage is lower than 70%Ue; 2) Examine if the failure is in under-voltage release and control unit.
	Machinery interlock operation	Examine working situation of circuit breaker with two sets of machinery interlock.
Fail to Switch ON	No attracting on under-voltage release	1) If under-voltage release is power on; 2) Examine if the voltage is lower than 70%Ue; 3) Examine if under-voltage release burns out, if burning out, please replace it.
	No resetting on resetting button	Press the resetting button to close the circuit breaker.
	Draw-out circuit breaker is not shaken into the position	Shake draw-out circuit breaker into the position (until crack sound)
	Poor contact in secondary circuit of draw-out circuit breaker	Examine the contact of secondary circuit and recover.
	No energy storage of circuit breaker	1) Examine if control power of electromotor is power on and it should be not less than 85%Us; 2) Examine if energy storage of electromotor has the failure.
	The machinery interlock operation and the circuit breaker are locked.	Examine if machinery interlock of two sets of circuit breakers work normally.
	Problems in off-switch electromagnet	1) Examine if off-switch electromagnet power is power on and it should be not less than 85%Us; 2) If problems in off-switch electromagnet and no attracting, please replace it.
	Connection error in shunt release	The shunt release should be connected with normal open point of button switch.
Close the switch after switching in	1) Immediate tripping 2)Time delay tripping	1) Examine if there is short circuit current on the circuit; 2) Examine if there is overload current on the circuit; 3) Examine if the button of shunt release is in wrong connection, press the resetting button to close the switch for the circuit breaker.
No breaking	1) No electric breaking 2)No manual breaking	1) Examine if shunt release is in reliable circuit connection and has failure, if confirmed failure, replace it. 2) Examine if there is machinery failure on operation.
No energy storage	1)No manual energy storage 2) No electric energy storage	1) Examine the voltage of control power of electric energy storage should be not less than 85%Us; if there are problems on circuit connection. 2) Examine if there are problems on electromotor.

Table 11 (continued)

Do not draw out while the draw-out circuit breaker is in "separation" position	<ol style="list-style-type: none"> 1) Not draw out the handle 2) The circuit breaker hasn't completely reached "separation" position. 	<ol style="list-style-type: none"> 1) Draw out the handle; 2) Completely shake the circuit breaker into "separation" position.
Do not shake the circuit breaker into "connection" position	There are foreign bodies into base and clapping the shaking body or driven body and the gear is damaged.	Examine foreign body, rack and gear
No indication on the screen of intelligent controller	<ol style="list-style-type: none"> 1) No power connected to intelligent controller 2) Abnormal in auxiliary power input terminal and voltage 3) Abnormal in secondary output of base frame transformer 4) No reliable connection between secondary output of base frame and controller 	<ol style="list-style-type: none"> 1) Examine intelligent controller power connection 2) Cut-off intelligent controller power, then switch on the power, if the failure still exists, it may replace the controller.
Abnormal communication of H-shaped controller	<ol style="list-style-type: none"> 1) No reliable connection between communication line and connecting terminal of circuit breaker 2) Converse connection between A and B terminal of communication line 3) Problems in communication distance and connection method 4) Problems in communication address setting of circuit breaker 	<ol style="list-style-type: none"> 1) Examine if the connection between communication line and connecting terminal of circuit breaker is reliable or in wrong connection; 2) Examine if connection between A and B terminal of communication line is converse, if converse, please adjust it 3) Examine if communication distance and connection method comply with the requirements; 4) Examine if communication address setting of circuit breaker is correct and it has no conflict.
Intelligent Controller	Over-high surrounding temperature of controller	Lower surrounding temperature. Note: E-80 means inner temperature of controller is over-high, beyond 80°C+5°C.

9. Order instruction

While ordering, please fill in the following form.

Quantity	Set		
Model	Available type and rated current		Rated voltage <input type="checkbox"/> AC400V <input type="checkbox"/> AC690V
YCW3-1600	<input type="checkbox"/> 200 <input type="checkbox"/> 400 <input type="checkbox"/> 630 <input type="checkbox"/> 800 <input type="checkbox"/> 1000 <input type="checkbox"/> 1250 <input type="checkbox"/> 1600	Quantity Set	<input type="checkbox"/> Fixed <input type="checkbox"/> Draw-out <input type="checkbox"/> Three poles <input type="checkbox"/> Four poles
YCW3-2000	<input type="checkbox"/> 630 <input type="checkbox"/> 800 <input type="checkbox"/> 1000 <input type="checkbox"/> 1250 <input type="checkbox"/> 1600 <input type="checkbox"/> 2000	Quantity Set	<input type="checkbox"/> Fixed <input type="checkbox"/> Draw-out <input type="checkbox"/> Three poles <input type="checkbox"/> Four poles
YCW3-2500	<input type="checkbox"/> 630 <input type="checkbox"/> 800 <input type="checkbox"/> 1000 <input type="checkbox"/> 1250 <input type="checkbox"/> 1600 <input type="checkbox"/> 2000 <input type="checkbox"/> 2500	Quantity Set	<input type="checkbox"/> Fixed <input type="checkbox"/> Draw-out <input type="checkbox"/> Three poles <input type="checkbox"/> Four poles
YCW3-3200	<input type="checkbox"/> 2500 <input type="checkbox"/> 2900 <input type="checkbox"/> 3200	Quantity Set	<input type="checkbox"/> Fixed <input type="checkbox"/> Draw-out <input type="checkbox"/> Three poles <input type="checkbox"/> Four poles
YCW3-4000	<input type="checkbox"/> 3200 <input type="checkbox"/> 3600 <input type="checkbox"/> 4000	Quantity Set	<input type="checkbox"/> Fixed <input type="checkbox"/> Draw-out <input type="checkbox"/> Three poles <input type="checkbox"/> Four poles
YCW3-6300	<input type="checkbox"/> 4000 <input type="checkbox"/> 5000 <input type="checkbox"/> 6300	Quantity Set	<input type="checkbox"/> Fixed <input type="checkbox"/> Draw-out <input type="checkbox"/> Three poles <input type="checkbox"/> Four poles

Intelligent controller	Basic function	<input type="checkbox"/> Overload long-time delay protection <input type="checkbox"/> Short time delay protection <input type="checkbox"/> short circuit instantaneous protection
	Other function	<input type="checkbox"/> Grounding protection <input type="checkbox"/> Load monitoring <input type="checkbox"/> Ammeter function <input type="checkbox"/> MCR function <input type="checkbox"/> Thermo-analogue <input type="checkbox"/> Voltage Meter function <input type="checkbox"/> Self-diagnosis <input type="checkbox"/> Testing <input type="checkbox"/> Failure memory <input type="checkbox"/> Communication
	Power	<input type="checkbox"/> AC 230V <input type="checkbox"/> AC 400V <input type="checkbox"/> DC 220V <input type="checkbox"/> DC 110V
Accessory	<input type="checkbox"/> Under-voltage release	<input type="checkbox"/> AC 230V <input type="checkbox"/> AC 400V <input type="checkbox"/> Under-voltage instantaneous release <input type="checkbox"/> Under-voltage instantaneous release <input type="checkbox"/> 1s <input type="checkbox"/> 3s <input type="checkbox"/> 5s <input type="checkbox"/> 10s
	<input type="checkbox"/> Shunt release	<input type="checkbox"/> AC 230V <input type="checkbox"/> AC 400V <input type="checkbox"/> DC 220V <input type="checkbox"/> DC 110V
	<input type="checkbox"/> Energy-releasing electromagnet	<input type="checkbox"/> AC 230V <input type="checkbox"/> AC 400V <input type="checkbox"/> DC 220V <input type="checkbox"/> DC 110V
	<input type="checkbox"/> Motor-driven	<input type="checkbox"/> AC 230V <input type="checkbox"/> AC 400V <input type="checkbox"/> DC 220V <input type="checkbox"/> DC 110V
	<input type="checkbox"/> Auxiliary switch	<input type="checkbox"/> 4 groups of switches <input type="checkbox"/> 4 NO 4 NC <input type="checkbox"/> 3 NO 3 NC <input type="checkbox"/> 2 NO 6NC <input type="checkbox"/> 6 NO 4 NC
	<input type="checkbox"/> Machinery interlock	<input type="checkbox"/> Horizontal interlock <input type="checkbox"/> Vertical interlock <input type="checkbox"/> Gate interlock <input type="checkbox"/> Others
Note: 1: Please mark <input checked="" type="checkbox"/> in the form, a piece for each specification in principle. Indicate the number of set for the same specification. 2. If users have a special order, please contact with our technical department.		

10. Promise

We provide three-promise for quality issues, while it should be under normal storage, maintenance and use in 18 months from the production date.



CERTIFICATE

Product Model: YCW3 series

Standard : IEC 60947-2

Inspector : CNC 009

Production date: Printed on the product
or package.

This product is qualified according
to the delivery inspection

CNC

YCW3 series

CNC ELECTRIC

Tel: 0086-577-61989999 Fax: 0086-577-61891122

www.cncele.com E-mail: cncele@cncele.com